

RAPTOR DESIGN & ENGINEERING LLC

MANUFACTURER OF



XTR RESCUE RAPTOR 1860 & 1560

1. *General Specifications*

- 1.1. Rigid Hull – Inflatable Boat
 - 1.1.1. Rigid Hull Material: Aluminum
 - 1.1.2. Inflatable Collar Material: Urethane
- 1.2. Hull Shape: Modified V
- 1.3. Propulsion: Inboard Jet
- 1.4. Internal Layout: Walk-Around Center Console Forward, Open Bow, Boxed Engine Compartment
- 1.5. Overall Length: 1860 = 18'2" or 1560 = 14'11"
- 1.6. Bow Tip To Transom Length: 1860 = 16'3" or 1560 = 13'2"
- 1.7. Bottom Width: 60"
- 1.8. Beam: 83"
- 1.9. Side Height: 27"
- 1.10. Deadrise: 10 Degree
- 1.11. Static Draft: 7 – 8"
- 1.12. Draft On Plane: 3"
- 1.13. Top Speed 50 mph with 300 hp engine, 43 mph with 170 hp engine
- 1.14. Fuel Consumption: 7 gph @ 30 mph
- 1.15. US Coast Guard Compliant Construction



375 New
Holland
Drive
Suite A
Belleville,
PA
17004
USA

PHONE 717-935-2175
EMAIL info@riverraptorjetboats.com
WEBSITE www.riverraptorjetboats.com

2. Hull Specifications

2.1. Aluminum Hull (Boat Bottom & Lower Sides)

- 2.1.1. AL 5052 Sheet Material (Ultimate Tensile Strength 33,000 psi)
- 2.1.2. AL 6061 Extrusions
- 2.1.3. .190" Bottom
- 2.1.4. .125" Sides, Aluminum Collar Cradle, Keder Rail For Collar Attachment
- 2.1.5. .125" Floor Panels
- 2.1.6. Raised Performance Jet Intake System (Dimensions: 13" Wide X 20" Long X 1.75" Deep)
- 2.1.7. Double Mig Welded (Inside & Outside) Hull Seams
- 2.1.8. Custom Build Heavy Duty Infrastructure
- 2.1.9. Engineered, Laser Notched (To Reduce Weight & Provide Access To UHMW Hardware) C Channel & .25" X 2" C Channel Continuously Welded Bottom Stringers
- 2.1.10. Custom Build Floor Support Structure Welded To Stringers
- 2.1.11. Floor Panels Attached To Floor Support Structure Via 3M 540 & Aluminum Rivets
- 2.1.12. Pump Protection Tubing (1 3/4" O.D., 0.125" WALL, AL) Connecting Swim Deck & Transom Reinforced With Cross Brace
- 2.1.13. Self-Baling Deck System – 4 Longitudinal Floor Channels That Direct Water To 4 Transom Mounted Scupper Valves
- 2.1.14. Hull is of rugged, heavy-duty design to minimize damage from impact and abrasion as a result of contacting subsurface objects.

2.2. Collar System (Boat Higher Sides)

- 2.2.1. Constructed of 40 oz Urethane Fabric
- 2.2.2. 14" Diameter
- 2.2.3. 5 Individual Chambers
- 2.2.4. 8" Side Rubstrake
- 2.2.5. 8" Bottom Rubstrake
- 2.2.6. D Ring Attached Collar Top Life Line
- 2.2.7. Grab Handles

3. Internal Layout

- 3.1. Center Forward Console Design
- 3.2. Walk Around Center Console With Polycarbonate Windshield, 4 Grab Handles, Sliding D-Ring Track, 4 D-Ring Pods & 8 Removable D-Rings
- 3.3. Bow Deck – 53" X 53"
- 3.4. Sit Down Operator's Station With Low-Back Helm Seat – 1560 Dual Leaner Seat With Storage - 1860
- 3.5. Rear Deck Engine Compartment Lid (54" X 22" Seating) With Lifting Shocks & Grab Handles
- 3.6. Swim Deck Extension – 52.5" X 20"



375 New
Holland Drive
Suite A
Belleville, PA
17004
USA

PHONE 717-935-2175
EMAIL info@riverraptorjetboats.com
WEBSITE www.riverraptorjetboats.com

4. Drive System Specifications:

- 4.1. Engine: BRP Rotax 1630
 - 4.1.1. Horsepower: 300 or 170
- 4.2. Pump: BRP Rotax
 - 4.2.1. 160mm Diameter
 - 4.2.2. Axial Flow
 - 4.2.3. Cast Aluminum Reverse Bucket
 - 4.2.4. Stainless Steel Wear Ring
 - 4.2.5. Integrated Cooling Water Supply For Engine
- 4.3. Wet Exhaust System
- 4.4. Fuel Capacity: 1860 – 27 Gallon, 1506 - 19 Gallon (Aluminum Under Floor Fuel Tank To Maximize Fuel Capacity & Watercraft Stability)

5. Electrical Specifications

- 5.1. Rear Starboard Storage Located Electrical Center Containing:
 - 5.1.1. DEKA DKADP24 Starting Battery: 550 CCA, 120 Reserve Capacity At 25 Amps
 - 5.1.2. Engine Fuse Box
 - 5.1.3. BRP Rotax JPS BUDS Engine Data & Diagnostic System With Diagnostic Plug
 - 5.1.4. Main Electrical Panel Containing:
 - 5.1.4.1. Main Electrical Disconnect
 - 5.1.4.2. Positive Terminal Stud / Disconnect Circuit
 - 5.1.4.3. Positive Terminal Stud / Always On
 - 5.1.4.4. Ground Terminal Stud
 - 5.1.4.5. ATO Fuse Box
- 5.2. Medallion Helm Mounted 8" Touch Display
 - 5.2.1. Multifunction Touch Display: Clock, Fuel Level, Speed, Engine RPM, Engine Temperature, Fuel Consumption Rate (Instant), Compass, Hour Meter
 - 5.2.2. Indicator Lights: High Engine / Exhaust Temperature, High / Low Battery Voltage, Maintenance Required / Fault Code, Low Fuel, Low Oil Pressure, Check Engine
- 5.3. Key Switch
- 5.4. 1 – 8 Circuit Switch Panel
 - 5.4.1. Fused Switches:
 - 5.4.1.1. Blower
 - 5.4.1.2. Navigation Lights
 - 5.4.1.3. Manual Bilge
 - 5.4.1.4. Deck Lighting
 - 5.4.1.5. (4) Auxiliary/Lighting/Accessory
- 5.5. 12V Receptacle



375 New
Holland Drive
Suite A
Belleville, PA
17004
USA

PHONE 717-935-2175
EMAIL info@riverraptorjetboats.com
WEBSITE www.riverraptorjetboats.com

- 5.6. Helm Mounted Kill Switch With Lanyard (Fell Marine MOB Wireless Option Available)
- 5.7. 4" Marine Bilge Blower
- 5.8. Dual 900gph Automatic Bilge Pumps
- 5.9. TH-Marine LED Interior Strip Deck Lighting
- 5.10. Side Helm Recessed LED Front Navigation Lights
- 5.11. Rear Post Anchor Light
- 5.12. Sealed Amphinol Electrical Connectors At Electrical Harness Junctions & Terminals
- 6. Controls Specifications
 - 6.1. 135 Degree Helm Steering
 - 6.2. Flow-Tec SDR Shifter
 - 6.2.1. Single Lever/Dual Function
 - 6.2.2. Port Side Console Mount
 - 6.2.3. Start In Gear Protection
- 7. Deck Hardware
 - 7.1. Stainless Steel Hardware
- 8. Topside Finish
 - 8.1.1. AquaTraction Cross-Link Polyethylene Marine Flooring – Customer Choice Of Color Scheme
 - 8.1.2. Customer Service Logo Laser Etched In Engine Compartment Lid
 - 8.2. Decals
 - 8.2.1. River Raptor Console Logo
- 9. Additional Options & Accessories Available Upon Request
 - 9.1. ½" UHMW Bottom & Side Coating With Steel Plate Reinforcement Around Intake
 - 9.2. Winch (3500 lb – Bow Mounted)
 - 9.3. 24V Portable Cordless Winch
 - 9.4. Anchor & Anchor Nest
 - 9.5. Fore-Console Or Under Seat Cooler/Seat/Storage Box
 - 9.6. Light Bar Loop – Rear Mounted (Customizable Search & Warning Lighting)
 - 9.7. Light Bar – Bow Mounted Quick-Detach
 - 9.8. Compact Light Tower
- 10. 3D Model & 2D Technical Drawings
 - 10.1. A 3D AutoCAD Inventor Model Will Be Made Available Upon Request For Project Approval Prior To Project Construction
 - 10.2. 2D Drawings Will Be Made Available For Project Approval Prior To Project Construction
- 11. Training
 - 11.1. A qualified, manufacturer authorized and trained service representative can offer training at the request of the customer. This training will be at the cost of the customer.



375 New
Holland Drive
Suite A
Belleville, PA
17004
USA

PHONE 717-935-2175
EMAIL info@riverraptorjetboats.com
WEBSITE www.riverraptorjetboats.com

12. Commercial Use Warranty

- 12.1. Scope – Entire Body & Accessories
- 12.2. Time Period – 1 Year
- 12.3. Guarantee – Free Of Original Material & Workmanship Defects

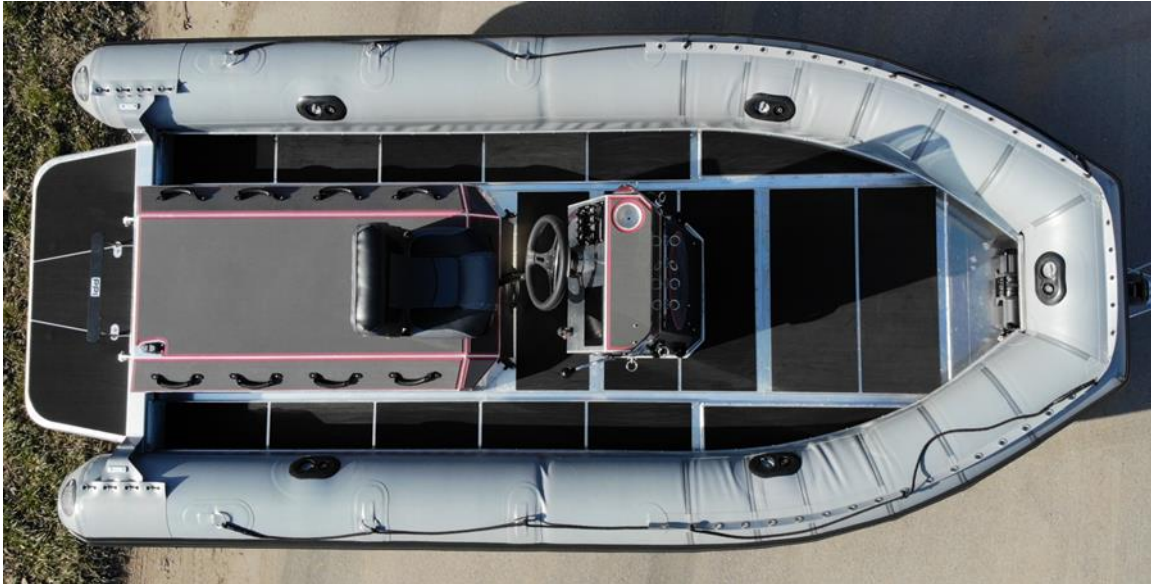

375 New
Holland Drive
Suite A
Belleville, PA
17004
USA

PHONE 717-935-2175
EMAIL info@riverraptorjetboats.com
WEBSITE www.riverraptorjetboats.com



RAPTOR
DESIGN & ENGINEERING

375 New
Holland Drive
Suite A
Belleville, PA
17004
USA

PHONE 717-935-2175
EMAIL info@riverraptorjetboats.com
WEBSITE www.riverraptorjetboats.com

BUILD DETAILS	
ITEMS	VALUE
MODEL	XTR 1560
LENGTH	15'
WIDTH	60"
ENGINE	170 HP, ROTAX
BOTTOM THK	0.190
COLLAR MATERIAL	GREY URETHANE
COLLAR PRESSURE	2.5 PSI
FUEL CAPACITY	20 GAL.
BOW STORAGE	STANDARD
STOMP GRATE	STANDARD
BOTTOM UHMW	YES
SIDE UHMW	YES
AQUATRACON COLOR	CHARCOAL ON RED
BOW COOLER/SEAT	NO
TRAILER	CUSTOM, DUAL

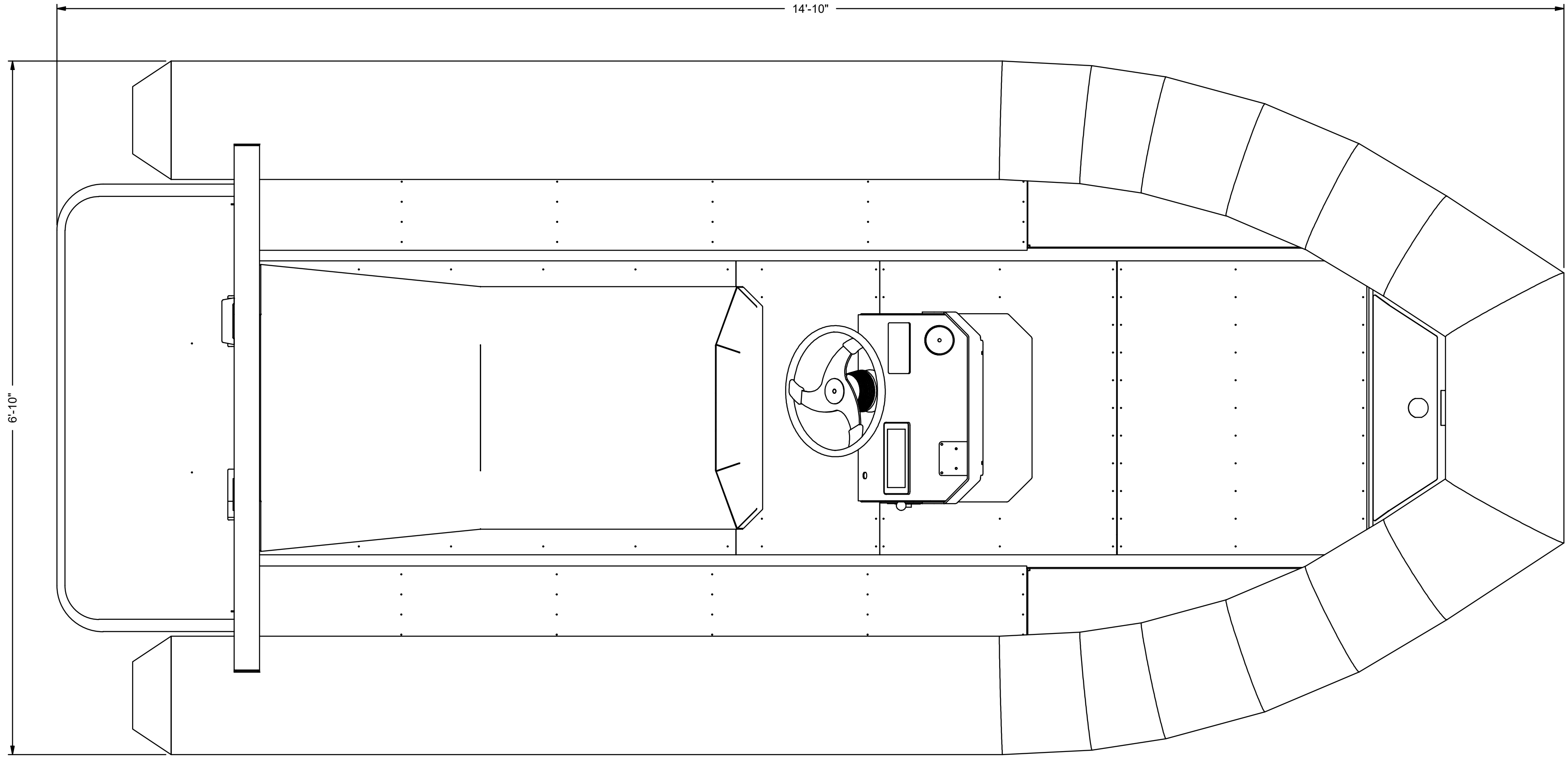

TOP VIEW
SCALE 1:10

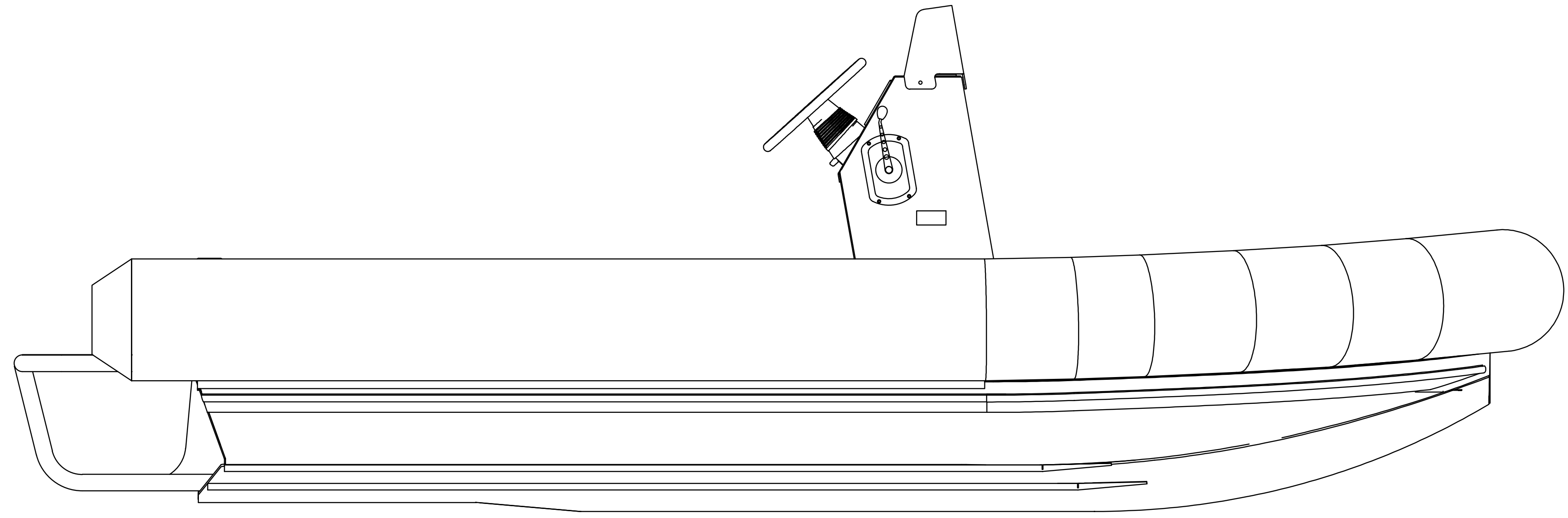

SIDE VIEW
SCALE 1:10

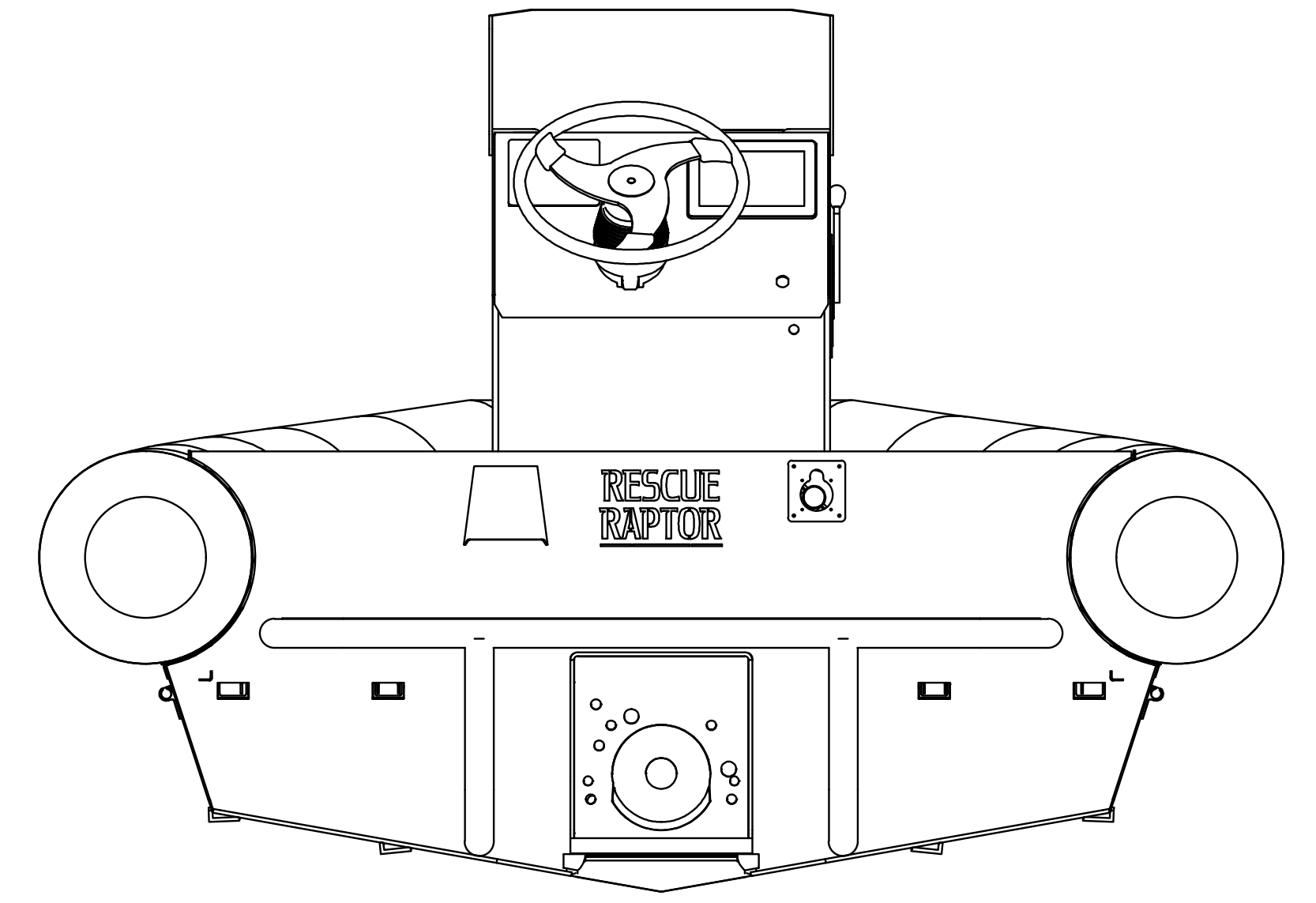

REAR VIEW
SCALE 1:10

BUILD DETAILS	
ITEMS	VALUE
MODEL	XTR 1860
LENGTH	15'
WIDTH	60"
ENGINE	170/300 HP, ROTAX
BOTTOM THK	0.190
COLLAR MATERIAL	GREY URETHANE
COLLAR PRESSURE	2.5 PSI
FUEL CAPACITY	27 GAL.
BOW STORAGE	STANDARD
STOMP GRATE	STANDARD
BOTTOM UHMW	YES
SIDE UHMW	YES
AQUATRACON COLOR	TBD
BOW COOLER/SEAT	NO
TRAILER	CUSTOM, DUAL

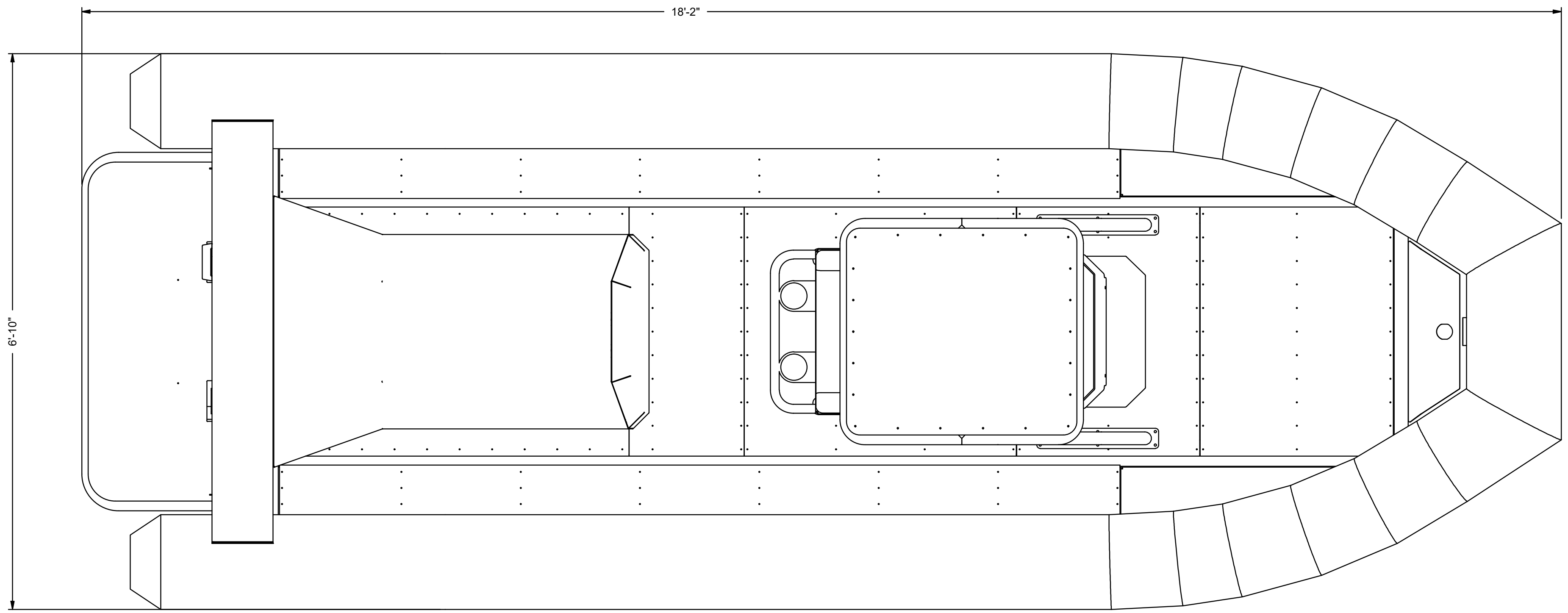

TOP VIEW
SCALE 1:12

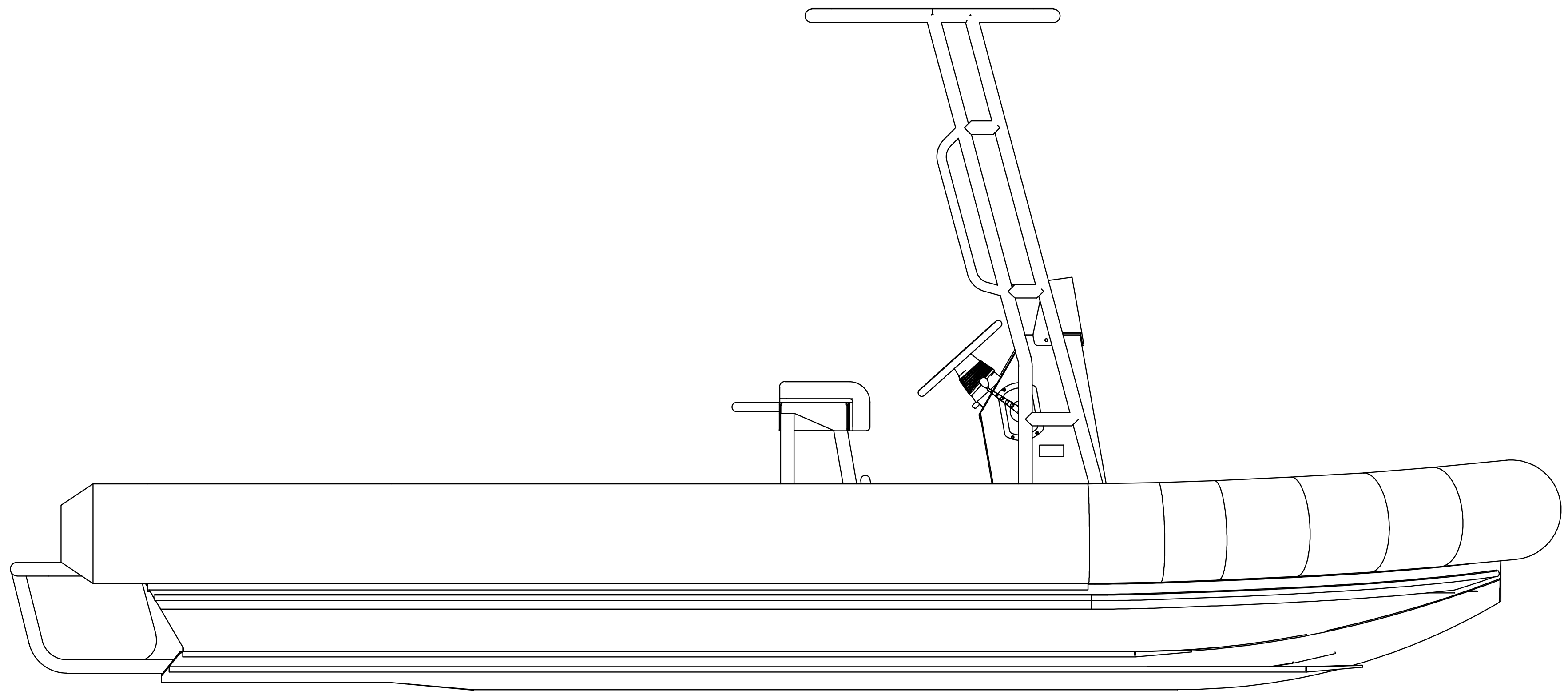

SIDE VIEW
SCALE 1:12

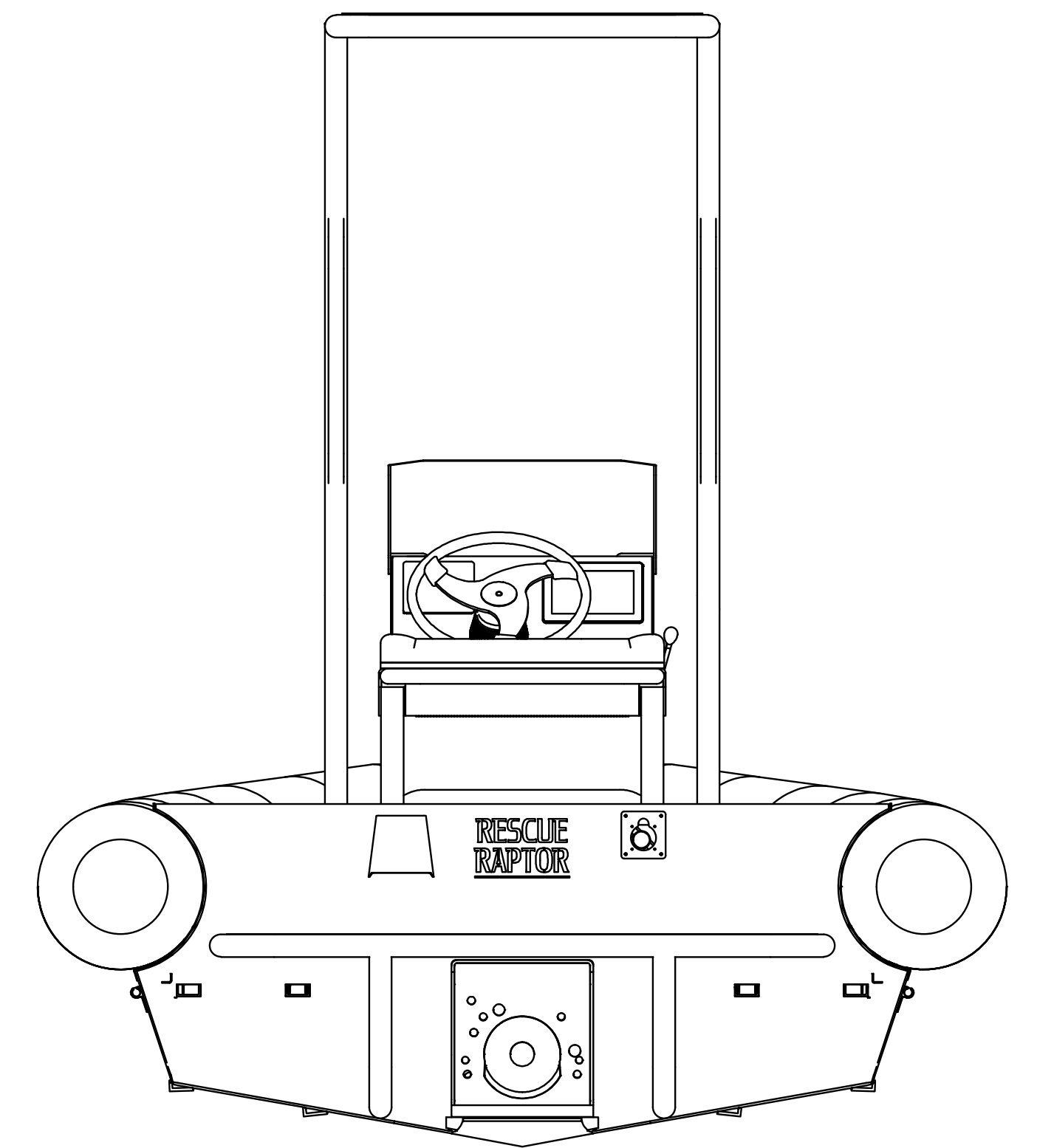

REAR VIEW
SCALE 1:12



1860 XTR FORWARD CONSOLE
SCALE 1:8

<small>THIS DRAWING IS THE PROPERTY OF RAPTOR DESIGN AND ENGINEERING AND SHALL NOT BE USED OR COPIED EXCEPT AS EXPRESSLY AUTHORIZED. ANY ABUSE OF THIS INFORMATION IS STRICTLY FORBIDDEN AND THE DESIGNER SHALL BE LIABLE FOR ANY AND ALL DAMAGES SUFFERED AS A RESULT.</small>	<small>UNLESS OTHERWISE NOTED, DIMENSIONS SHALL BE IN INCHES AND DECIMALS THEREOF. DIMENSIONS SHALL BE TO UNLESS OTHERWISE SPECIFIED.</small>	<small>DRAWN BY</small> RPlank	<small>CREATED</small> 11/22/2019	<small>WEIGHT</small> X LBS	<small>DRAWING NUMBER</small> D0146	<small>REVISION</small> 	<small>DESCRIPTION</small> XTR 1860	
		<small>CHECKED BY</small> RPlank	<small>ISSUED</small> AS SHOWN	<small>PART NUMBER</small> D0146-1860XTR	<small>SHEET</small> 27 OF 29	<small>SCALE</small> D		

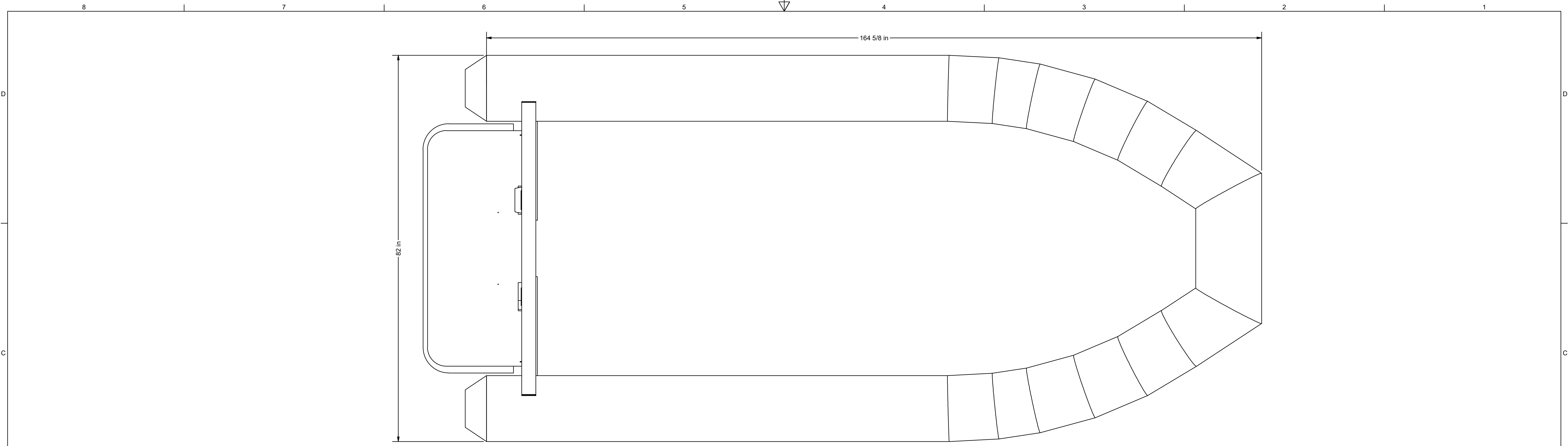

15' MODEL
SCALE 1:10

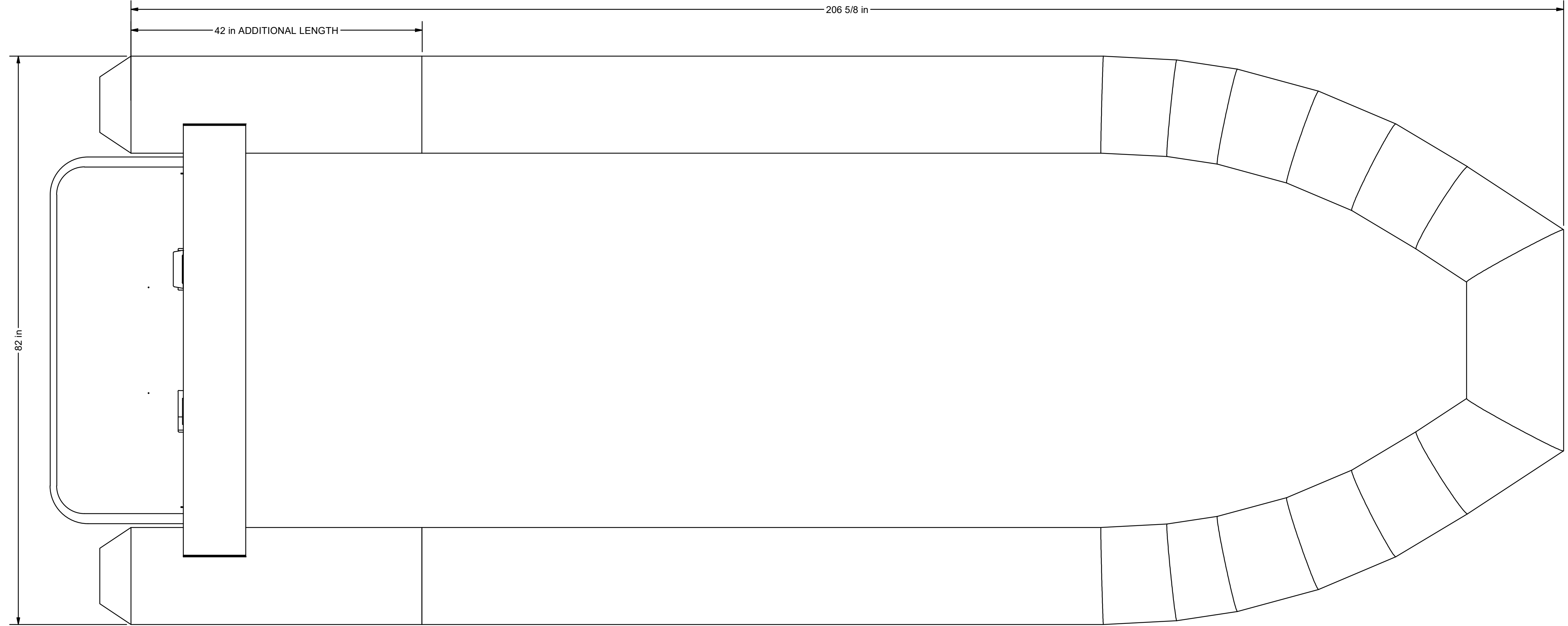

18' MODEL
SCALE 1:10

<small>THIS DRAWING IS THE PROPERTY OF RAPTOR DESIGN AND ENGINEERING AND SHALL NOT BE USED OR COPIED EXCEPT AS EXPRESSLY AUTHORIZED. ANY ABUSE OF THIS INFORMATION IS STRICTLY FORBIDDEN AND THE USER SHALL BE LIABLE FOR ANY AND ALL DAMAGES SUFFERED AS A RESULT.</small>		<small>DESIGNED BY: RPLANK DRAWN BY: RPLANK CHECKED BY: RPLANK ISSUED: AS SHOWN</small>		<small>CREATED: 11/22/2019</small> <small>SCALE: X LBS</small>	<small>DRAWING NUMBER: D0146</small> <small>PART NUMBER: D0146-1860XTR</small>	<small>REVISION: 1</small> <small>DESCRIPTION: XTR 1860</small>	<small>SHEET 28 OF 29</small>	
---	--	---	--	---	---	--	-------------------------------	--