

RAPTOR DESIGN & ENGINEERING LLC

MANUFACTURER OF

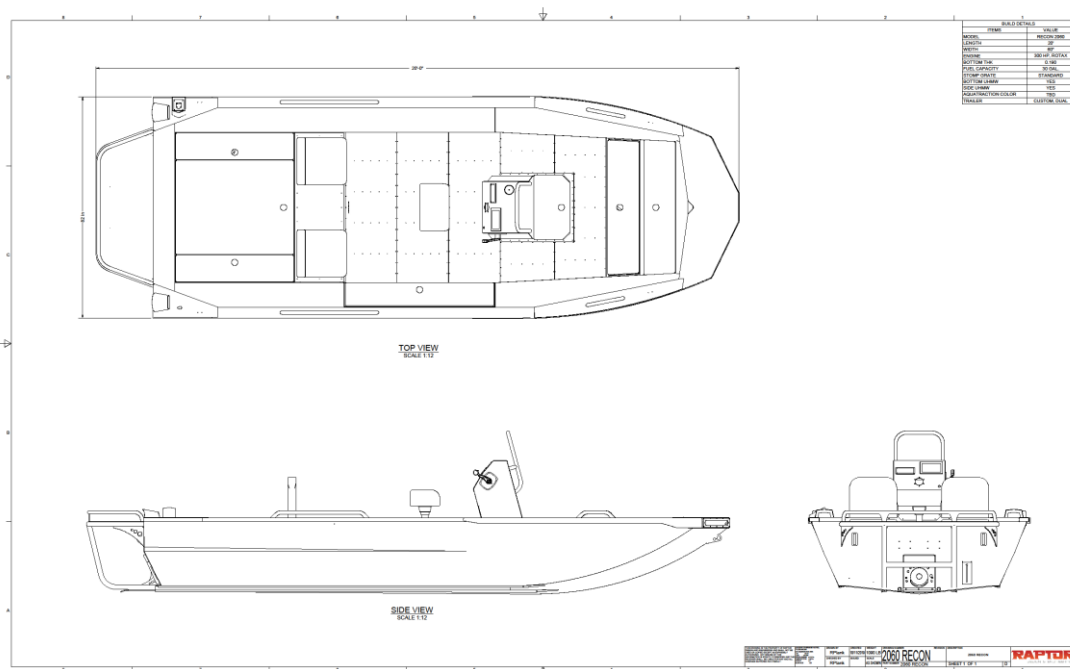

RIVER RAPTOR RECON 2060



375 New
Holland
Drive
Suite A
Belleville,
PA
17004
USA

PHONE 717-935-2175
EMAIL info@riverraptorjetboats.com
WEBSITE www.riverraptorjetboats.com

1. General Specifications

- 1.1. Hull Material: Aluminum
- 1.2. Hull Shape: Modified V
- 1.3. Propulsion: Inboard Jet
- 1.4. Internal Layout: Walk-Around Center Console Forward
- 1.5. Overall Length: 20'
- 1.6. Bow Tip To Transom Length: 18'2"
- 1.7. Bottom Width: 60"
- 1.8. Beam: 82"
- 1.9. Side Height: 27"
- 1.10. Deadrise: 6 Degree
- 1.11. Static Draft: 6 – 7"
- 1.12. Draft On Plane: 3"
- 1.13. Top Speed 41 – 43 mph (170 hp Variant), 49-52 mph (300 hp Variant)
- 1.14. US Coast Guard Compliant Construction

2. Hull Specifications

- 2.1. AL 5052 Sheet Material (Ultimate Tensile Strength 33,000 psi)
- 2.2. AL 6061 Extrusions
- 2.3. .190" Bottom (.250" Optional)
- 2.4. .125" Sides, Step Bent For Structural Integrity
- 2.5. .125" Floor Panels
- 2.6. Delta Pad Intake
- 2.7. Double Mig Welded (Inside & Outside) Hull Seams
- 2.8. Custom Build Heavy Duty Infrastructure
- 2.9. (5) Engineered, Laser Notched (To Reduce Weight & Provide Access To UHMW Hardware) C Channel Longitudinal Stringer Assemblies And (2) .25" X 3" Flat Bar Stringers Resulting In (12) Continuously Welded Vertical Leg Stringers
- 2.10. Custom Build Floor Support Structure Welded To Stringers
- 2.11. Floor Panels Attached To Floor Support Structure Via 3M 540 & Aluminum Rivets
- 2.12. Extended Rear Swim Deck At Same Elevation As Rear Deck
- 2.13. Pump Protection Tubing (1 3/4" O.D., 0.125" WALL, AL) Connecting Swim Deck & Transom Reinforced With Cross Brace
- 2.14. Sliding Transducer Bracket Welded To Transom (Optional)
- 2.15. Gunwale Grab Rails: Welded On (1 1/4" O.D. AL Tubing): 2 – 14.75", 4 – 36.75" (Optional)
- 2.16. Swim Deck Lip (Optional)
- 2.17. Swim Deck Railing (Optional)
- 2.18. Fold & Stow Boarding Ladder (Optional)



375 New
Holland Drive
Suite A
Belleville, PA
17004
USA

PHONE 717-935-2175
EMAIL info@riverraptorjetboats.com
WEBSITE www.riverraptorjetboats.com

- 2.19. Self-Draining Front & Rear Deck System That Directs Water To The Bilge
 - 2.20. Cleats: 4 (Port & Starboard Front & Rear)
 - 2.21. Hull is of rugged, heavy-duty design to minimize damage from impact and abrasion as a result of contacting subsurface objects.
3. Internal Layout
- 3.1. Center Forward Console Design
 - 3.2. Walk Around Center Console With Windshield & Integrated Grab Rail (1 ¼" O.D. AL Tubing)
 - 3.3. Fore Console Jump Seat With Grab Handles & Incorporated Storage
 - 3.4. Bow Platform With Removeable Storage Bin
 - 3.4.1. Platform Dimensions: 35" X 69"
 - 3.4.2. Storage Bin Dimensions: 42.75" X 6.5" X 9.5"
 - 3.5. Bow Step Box With Storage
 - 3.5.1. Opening Dimensions: 46.5" X 9.5"
 - 3.6. Cockpit Side Gun/Storage Locker (Port Or Starboard)
 - 3.6.1. Opening Dimensions: 54" X 10.5"
 - 3.6.2. Locker Dimensions: 116" X 6.5" X 10"
 - 3.6.3. Dual Gun/Storage Locker (Port & Starboard) Available
 - 3.7. Sit / Lean Helm Seat At Operator's Station
 - 3.8. Rear Cockpit Bench Seat – 55" X 18"
 - 3.9. Port & Starboard Gunwale Top Access Storage With Removable Storage Bins
 - 3.10. Large Rear Work Deck – 74" X 52"
 - 3.11. 2 Rear Deck Storage Compartments With Removeable Storage Bins
 - 3.12. Rear Deck Engine Compartment Lid With Lifting Shocks
 - 3.13. 21" X 56" Swim Deck Extension With Optional Grab Railing (1 ¼" O.D. AL Tubing)
 - 3.14. Bow Cap Access Panel
4. Drive System Specifications:
- 4.1. Engine: BRP Rotax 1630
 - 4.1.1. Horsepower: 170 hp (300 hp Optional)
 - 4.1.2. Naturally Aspirated 170 hp (Supercharged 300 hp Optional)
 - 4.1.3. External Intercooler On 300 hp Variant
 - 4.2. Pump: BRP Rotax
 - 4.2.1. 160mm Diameter
 - 4.2.2. Axial Flow
 - 4.2.3. Cast Aluminum Reverse Bucket
 - 4.2.4. Stainless Steel Wear Ring
 - 4.2.5. Integrated Cooling Water Supply For Engine
 - 4.3. Wet Exhaust System
 - 4.4. 23 Gallon Aluminum Cross-Hull Fuel Tank To Maximize Fuel Capacity & Watercraft Stability



375 New
Holland Drive
Suite A
Belleville, PA
17004
USA

PHONE 717-935-2175
EMAIL info@riverraptorjetboats.com
WEBSITE www.riverraptorjetboats.com

5. Electrical Specifications

- 5.1. Rear Starboard Storage Located Electrical Center Containing:
 - 5.1.1. DEKA DKADP24 Starting Battery: 550 CCA, 120 Reserve Capacity At 25 Amps (Lithium OR AGM Battery Optional)
 - 5.1.2. Engine Fuse Box
 - 5.1.3. BRP Rotax JPS BUDS Engine Data & Diagnostic System With Diagnostic Plug
 - 5.1.4. Main Electrical Panel Containing:
 - 5.1.4.1. Main Electrical Disconnect
 - 5.1.4.2. Positive Terminal Stud / Disconnect Circuit
 - 5.1.4.3. Positive Terminal Stud / Always On
 - 5.1.4.4. Ground Terminal Stud
 - 5.1.4.5. ATO Fuse Box
 - 5.1.4.6. CZONE Digital Switching Powder Distribution System
- 5.2. BRP Rotax Helm Mounted Instrument Cluster
 - 5.2.1. Multifunction Touch Display: Clock, Fuel Level, Speed, Engine RPM, Engine Temperature, Fuel Consumption Rate (Instant), Compass, Hour Meter
 - 5.2.2. Indicator Lights: High Engine / Exhaust Temperature, High / Low Battery Voltage, Maintenance Required / Fault Code, Low Fuel, Low Oil Pressure, Check Engine
 - 5.2.3. INR Override
 - 5.2.4. INR Adjustment
 - 5.2.5. Cole Hersee Key Switch
- 5.3. 1 – 2 Helm Mounted CZONE Switch Panel(s)
 - 5.3.1. Fused Switches:
 - 5.3.1.1. Blower
 - 5.3.1.2. Navigation Lights
 - 5.3.1.3. Manual Bilge
 - 5.3.1.4. Auxiliary/Lighting & Accessories As Needed
- 5.4. 12V Receptacle
- 5.5. Helm Mounted Kill Switch With Lanyard (Fell Marine MOB Wireless Option Available)
- 5.6. 4" Marine Bilge Blower
- 5.7. Dual 900gph Bilge Pumps
- 5.8. Side Hull Recessed LED Front Navigation Lights
- 5.9. Rear Post Anchor Light
- 5.10. Sealed Amphinol Electrical Connectors At Electrical Harness Junctions & Terminals

6. Controls Specifications

- 6.1. 135 Degree Helm Steering



375 New
Holland Drive
Suite A
Belleville, PA
17004
USA

PHONE 717-935-2175
EMAIL info@riverraptorjetboats.com
WEBSITE www.riverraptorjetboats.com

- 6.2. Livorsi INR (Intelligent Neutral & Reverse) Throttle / Shift Control
 - 6.2.1. Single Lever/Dual Function
 - 6.2.2. Port Side Console Mount
 - 6.2.3. Start In Gear Protection
- 7. Deck Hardware
 - 7.1. Hatch Latches – Lockable “T-Handle”
 - 7.2. Stainless Steel Hardware
 - 7.3. Stainless Steel Deck Lid Hinges
- 8. Topside Finish
 - 8.1. Paint
 - 8.1.1. Sikkens Polyurethane Industrial Coating
 - 8.1.2. Paint Color – Customer Provided Paint Code
 - 8.1.3. All Walking Surfaces Have Form Coat Non-Slip Coating Except When Other Non-Slip Marine Flooring Is Requested (AquaTraction Available)
 - 8.2. Decals
 - 8.2.1. Rescue Raptor Side Decals
 - 8.2.2. River Raptor Console Logo
- 9. Additional Options & Accessories Are Available Upon Request
- 10. 3D Model & 2D Technical Drawings
 - 10.1. A 3D AutoCAD Inventor Model Will Be Made Available Upon Request For Project Approval Prior To Project Construction
 - 10.2. 2D Drawings Will Be Made Available For Project Approval Prior To Project Construction
- 11. Training
 - 11.1. A qualified, manufacturer authorized and trained service representative can offer training at the request of the customer. This training will be at the cost of the customer.
- 12. Commercial Use Warranty
 - 12.1. Scope – Entire Body & Accessories
 - 12.2. Time Period – 1 Year
 - 12.3. Guarantee – Free Of Original Material & Workmanship Defects



375 New
Holland Drive
Suite A
Belleville, PA
17004
USA

PHONE 717-935-2175
EMAIL info@riverraptorjetboats.com
WEBSITE www.riverraptorjetboats.com



RAPTOR
DESIGN & ENGINEERING

375 New
Holland Drive
Suite A
Belleville, PA
17004
USA

PHONE 717-935-2175
EMAIL info@riverraptorjetboats.com
WEBSITE www.riverraptorjetboats.com



RAPTOR
DESIGN & ENGINEERING

375 New
Holland Drive
Suite A
Belleville, PA
17004
USA

PHONE 717-935-2175
EMAIL info@riverraptorjetboats.com
WEBSITE www.riverraptorjetboats.com

BUILD DETAILS	
ITEMS	VALUE
MODEL	RECON 2060
LENGTH	20'
WIDTH	60"
ENGINE	300 HP, ROTAX
BOTTOM THK	0.190
FUEL CAPACITY	30 GAL.
STOMP GRATE	STANDARD
BOTTOM UHMW	YES
SIDE UHMW	YES
AQUATRACCTION COLOR	TBD
TRAILER	CUSTOM, DUAL

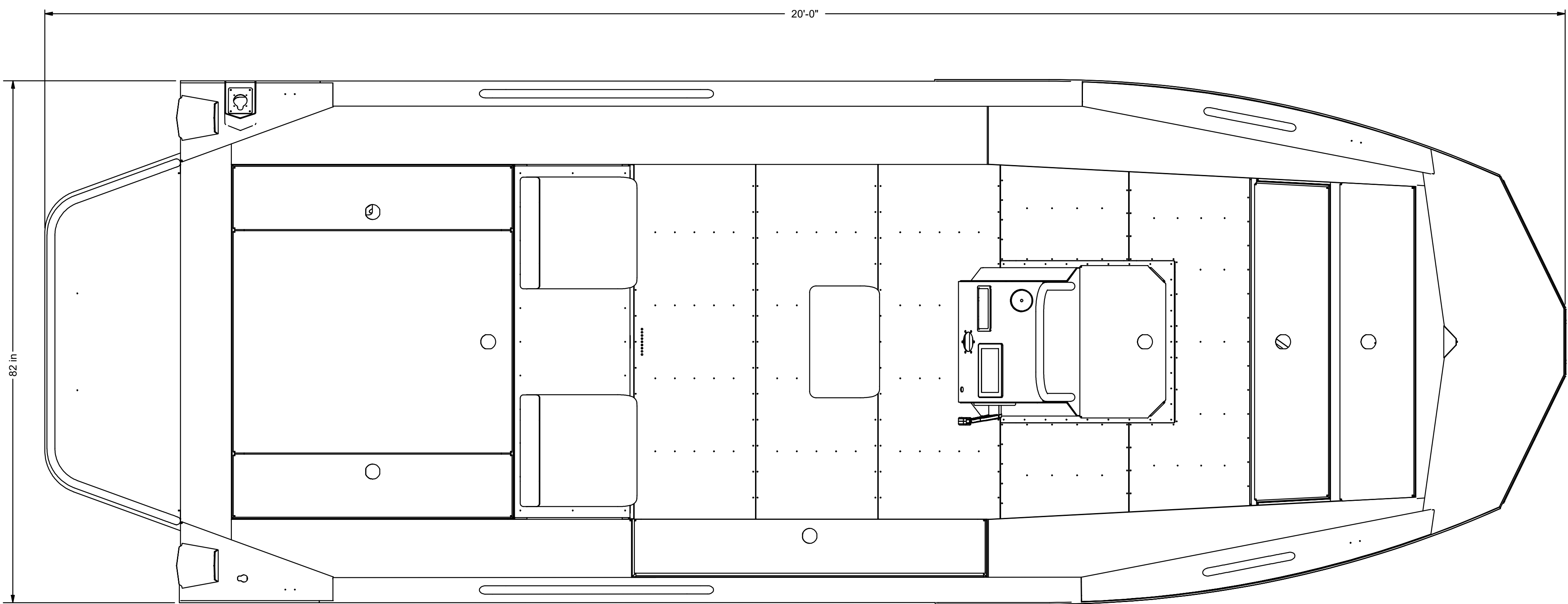

TOP VIEW
SCALE 1:12

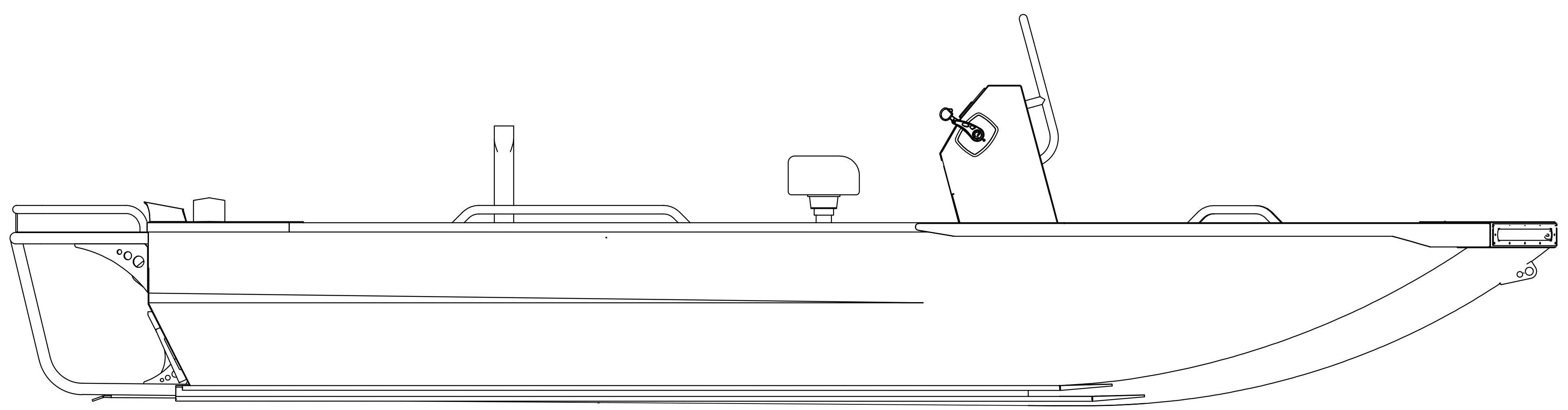

SIDE VIEW
SCALE 1:12

