

OWNER'S MANUAL SUPPLEMENT

Jet Drive Outboard BF150J / 105 Jet



Before operating your jet drive outboard for the first time, please read this Owner's Manual. Even if you have operated other jet driven outboards, take time to become familiar with how this jet drive outboard works and practice in a safe area until you build up your skills.

CONTENTS

WELCOME.....	2	SERVICING YOUR JET DRIVE	5	TROUBLESHOOTING.....	13
FOR YOUR SAFETY	2	Maintenance Safety.....	5	Poor performance.....	13
THEORY OF OPERATION.....	2	Maintenance Schedule	5	Outboard propels while in neutral.....	13
SIZING & APPLICATIONS	3	General Inspection	6	TECHNICAL INFORMATION.....	14
Selecting a Boat and Hull.....	3	Bearing Lubrication.....	6	Serial Number Location	14
Selecting an Outboard Motor	4	Reverse Gate Linkage.....	6	CUSTOMER INFORMATION.....	14
OPERATION	4	Salt Water Use.....	6	Register Your Jet Drive Outboard.....	14
Before Using Your Jet Drive Outboard	4	Impeller.....	6	Parts and Service Items.....	14
Steering	4	Shear Key Replacement.....	7	Dealer Locator Information	14
Operating in Shallow Water	4	JET DRIVE ASSEMBLY	8	How to Contact Honda.....	14
Intake Blockage.....	4	INSTALLATION & RIGGING.....	12	Honda Publications.....	14
Mooring	4	Remote Controls.....	12	Frequently Asked Questions.....	14
Throttle Control	5	Outboard Mounting.....	13	DISTRIBUTOR'S LIMITED WARRANTY	15
Reducing Spray and Cavitation.....	5			EMISSION CONTROL SYSTEM	
				WARRANTY	17

QUESTIONS?

Contact your Honda dealer.
There is a dealer locator at
marine.honda.com

HONDA MARINE



WELCOME

Congratulations on your selection of a Honda jet drive outboard motor! We are certain you will be pleased with your purchase of one of the finest jet driven outboards on the market. We want to help you get the best results from your new jet drive outboard and to operate it safely. This manual contains information on how to do that for only the jet drive portion of your outboard; please read it carefully. Use this owner's manual supplement in conjunction with the Honda Marine BF150A owner's manual supplied with the outboard motor's powerhead.

When your jet driven outboard needs scheduled maintenance, keep in mind that Honda Marine servicing dealership personnel are specially trained in servicing Honda outboards and are supported by the parts and service divisions of American Honda.

Please read the *DISTRIBUTOR'S LIMITED WARRANTY* on page 15, and the *EMISSION CONTROL SYSTEM WARRANTY* on page 17 to fully understand what is covered by warranty and your responsibilities of ownership.

FOR YOUR SAFETY

Your safety and the safety of others are very important. We have provided important safety messages in this manual. This information alerts you to potential hazards that could hurt you or others. Please read these messages carefully.

Of course, it is not practical or possible to warn you about all the hazards associated with operating or maintaining an outboard motor. You must use your own good judgment.

Safety Instructions

You will find important safety information in a variety of forms:

- **Instructions** – how to use this outboard correctly and safely
- **Safety Messages** – preceded by a safety alert  symbol and one of three signal words: DANGER, WARNING, or CAUTION. Each message tells you what the hazard is, what can happen, and what you can do to avoid or reduce injury. These signal words mean:

 **DANGER** You **WILL** be KILLED or SERIOUSLY HURT if you don't follow instructions.

 **WARNING** You **CAN** be KILLED or SERIOUSLY HURT if you don't follow instructions.

 **CAUTION** You **CAN** be HURT if you don't follow instructions.

- **Damage Prevention Messages** – you will also see other important messages that are preceded by the word NOTICE. This word means:

NOTICE Your engine, property, or the environment can be damaged if you don't follow instructions.

WARNING

The engine exhaust from this product contains chemicals known to the State of California to cause cancer, birth defects, or other reproductive harm.

California Proposition 65

This product contains or emits chemicals known to the State of California to cause cancer, birth defects, or other reproductive harm.

THEORY OF OPERATION

Jet driven outboards were designed to allow boats to operate in very shallow water such as creeks, rivers, or other waterways that are inaccessible to normal propeller-driven boats.

A jet driven outboard works by drawing water into the jet drive unit by an impeller that is driven directly by the engine's driveshaft. This water is then forced at high pressure and volume through a nozzle directed astern of the boat. The velocity imparted to this mass of water creates an opposite force, and drives the boat forward.

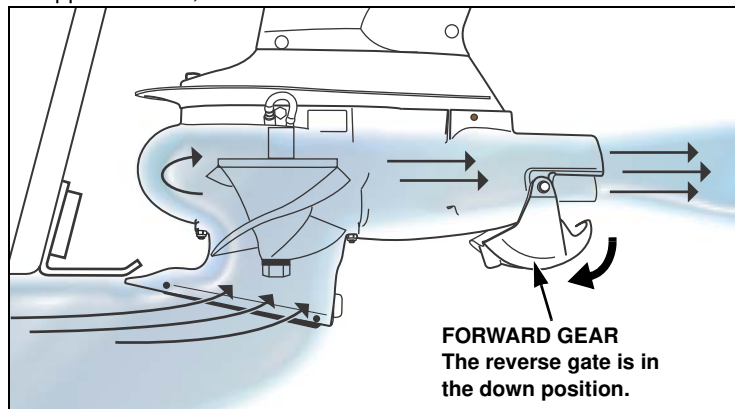

To drive the boat backward, the operator shifts the outboard into reverse causing a curved mechanical gate to move into the stream of water that exits the nozzle. This gate redirects the water into the opposite direction, and the thrust of the redirected water propels the boat backward.

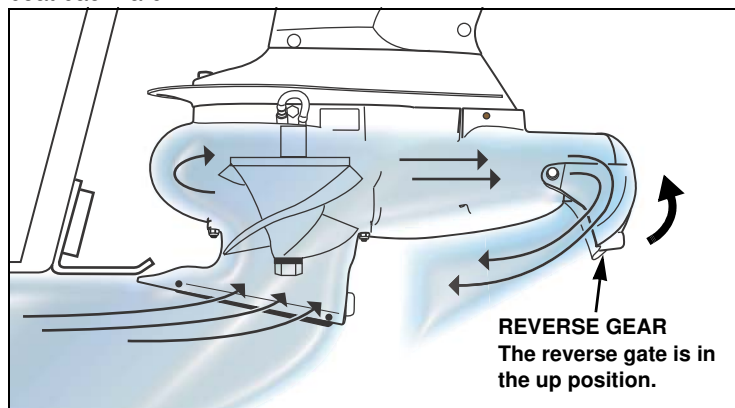

-sizing & Applications

Selecting a Boat and Hull

Combining the correct outboard power and boat design is the secret of successfully using an outboard jet to run in shallow water. The most important part is selecting the boat. Choose a boat that is as light as possible. Unlike a propeller drive, you cannot change to a lower pitch jet drive impeller to increase load capacity.

Aluminum is usually the material of choice for a jet driven boat. It is light, tough, and easy to form in the proper configuration. For outboard jets, the bottom thickness can range from 1/16 in (1.6 mm) for 20 to 50 hp applications to 3/16 in (4.8 mm) for motors up to 225 hp. The thinner gauge is more easily damaged whereas the thickest gauge can be a weight problem on midrange power from 50 - 100 hp motors. Aluminum boats are preferred because they usually have optimum hull designs, while being durable and lightweight.

The size and shape of the bottom of the boat is very important. The object is to ride on top of the water, which requires a good planing surface, and to float as shallow as possible when shut down.

The bottom of the boat should be at least 48 inches wide, and the centerline of the boat length should be at least 13 feet long. 6° to 9° of deadrise is good. Air entering the jet drive causes slippage, so the boat bottom needs to supply solid water (free of air) to the jet drive intake.

No one boat can satisfy every need, so choices must be made. With this in mind, some pros and cons of various boat types and characteristics are listed below.

Inflatables

Inflatables are light, easy to transport, and bounce off rocks nicely. However, due to the flexible nature of their bottom, they trap and introduce air into the jet intake. Steering can be unpredictable or inconsistent when running light and while in crosswinds.

A rigid hull inflatable, on the other hand, cannot be folded to fit inside your car but steers better and provides solid water to the intake. Unfortunately, most rigid inflatable hulls that are currently available have more than 10° of deadrise.

Pontoon Boats

Pontoon boats do not provide a defined height apron of water ahead of the jet intake. The water level between the pontoons varies with speed and load carried. It is necessary to build an inclined plane ahead of the jet intake attached to the motor mount, that is approximately 16 inches wide, and inclined approximately 15° with the leading edge above the water level when the boat is fully loaded at rest. The trailing edge should be lined up with the leading edge of the jet intake.

Flat Bottom Boats

A flat bottom boat runs shallower than a vee bottom boat, but slides on the turns more. A vee bottom splits off air bubbles before they reach the jet intake. A flat bottom carries bubbles straight back.

Vee Hulls

A shallow vee of 6° to 10° of deadrise will enhance jet boat handling. A deep vee or multi-vee design is not desirable for a jet drive outboard, not just because of the increased draft and drag, but because the jet drive outboard needs a flat apron of water about 10 inches wide leaving the hull on which to set the leading edge of the jet intake, to minimize air intake and frontal drag. The deadrise should be fairly constant and not increase to a deep forefoot at the bow. A deep forefoot can cause a boat to spin out on a sharp turn.

Hull Tunnels

A properly designed tunnel, combined with a slight vee bottom hull can greatly enhance jet boat performance. It should raise the motor two to three inches, and place the heel of the jet intake flush or slightly above the bottom of the boat.

A jet tunnel does not work well with a flat bottom boat due to the air ingestion! It's imperative that the hull is designed correctly with the tunnel for the boat to operate properly.

The top of the tunnel width should be about 1-3/4 times the width of the jet drive water intake. The tunnel length does not have to be longer than approximately 2-1/2 times the water intake width.

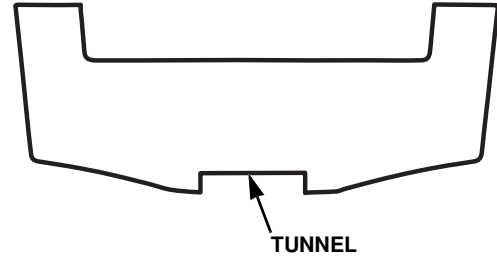

Chines and Keels

The chines of a boat are where the boat's sides meet the bottom. The chines should be sharp angles. Round chines tend to suck the boat down in the water and cause drag.

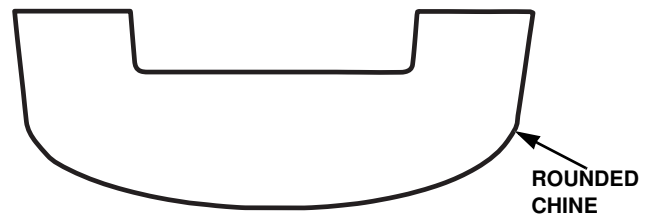
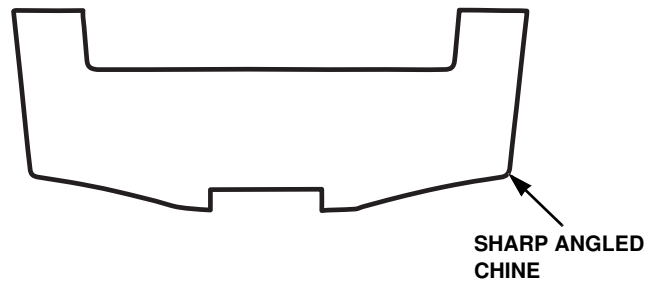

Keels can be a problem by introducing air into the jet intake. Center keels vary in size and may introduce air. If this is suspected, the keel should stop two to three feet forward of the transom. Other keel arrangements which tend to funnel air to the jet intake should be avoided.

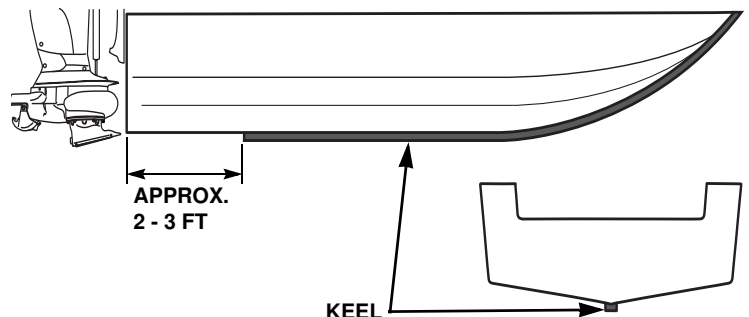

Selecting an Outboard Motor

A boat operating at slow speed requires considerably more water depth than one that is planing on the surface of the water. Therefore, it is important to use sufficient horsepower and not to overload your boat beyond its ability to plane. The following table shows the amount of horsepower that is needed in relation to the gross weight of the boat. This information is based on experience gathered with sled-type boats powered by jet driven outboards. Gross weights shown include the boat, motor, passengers, fuel, and gear.

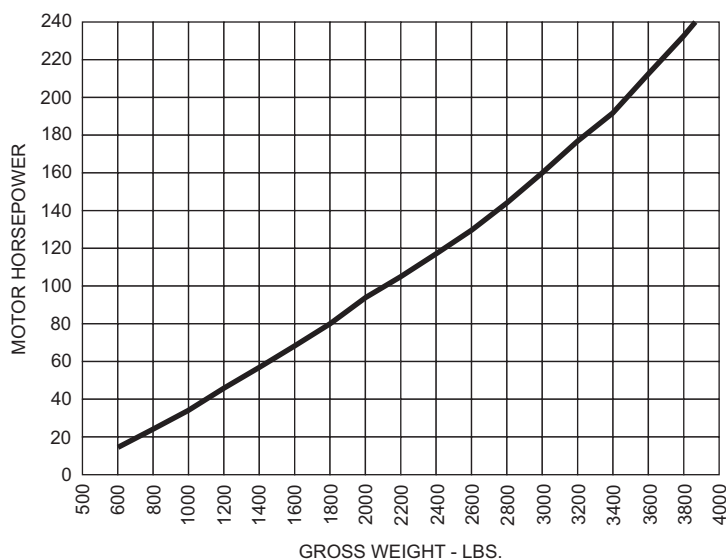

NOTE: The performance of jet driven outboards do not reflect the true performance of the same outboard motor that is driven by a propeller. On average, a jet driven outboard produces approximately 70% of the power of the same outboard motor that is propeller driven.

OPERATION

The following sections will provide important information and tips on how to get the most out of your jet driven outboard.

Before Using Your Jet Drive Outboard

All outboard motor operators must read the following sections:

- **FOR YOUR SAFETY** ([page 2](#))
- **OPERATION** ([page 4](#))
- **SERVICING YOUR JET DRIVE** ([page 5](#))

Steering

Experiment with steering your boat in an open area before attempting downstream river running. You will find quick response to the helm, but due to the relatively flat bottom hulls and lack of propeller keel, your boat will tend to skid on the turns. You must start your turns early and use sufficient power to maintain steerage. If you attempt to turn too tight at too high of a speed, your boat will likely spin out. This is a great way to stop in a hurry but is not recommended because it can cause an unstable boat to roll over.

Running upstream is the easiest. Remember that when running downstream, your speed relative to the shore is the speed of the river added to your boat speed.

When running upstream, your speed relative to the shore is the speed of your boat minus the speed of the river. You can throttle back and pick your way up through tight areas with good control. At that time, you should stop and study the layout looking downstream, so that you will recognize it on the return, downstream run. Once through, you

may wish to run down and back up the same stretch to memorize the course you take.

If you are not sure of a tight area on a downstream run, it is better to drift through on the oars with the outboard motor tipped up, or else line the boat through on a rope.

Operating in Shallow Water

The life of the impeller and water intake can be greatly increased by avoiding the intake of sand and gravel. The intake suction, acting on the river bottom, will act like a dredge when the intake comes within two or three inches of the bottom. It is best to shut off the outboard motor and drift up to the beach when landing, and to shove off with an oar when leaving the beach. You can idle through areas less than one foot deep, but there should be more than one foot of water under the boat when opening the throttle to reach a plane.

Once planing, the boat speed will prevent sucking in gravel. The suction is still acting, but the water intake passes over the river bottom so quickly that the boat is gone before the rocks have time to lift off the bottom.

To run in a shallow area, pay attention to the river conditions and what the river bottom is made up of, decide your course, and then if you feel safe, run through on a full plane. The faster you go, the higher the boat will ride. Be sure you know the river's bottom before attempting to go through on a full plane.

This should pose no problems if the river bed is sand and gravel. If you end up running high and dry, shut off the outboard motor immediately and drag the boat off to deeper water. However, if the river bed is full of sharp, larger rocks, you run the risk of damaging your hull, injuring yourself, and potentially walking home.

Gravel passing through the pump will round over the leading edge of the impeller blades. For maximum performance, file these edges occasionally to keep them sharp as when new.

Occasionally, on running aground, a small rock will jam between the impeller and the intake wall, and the outboard motor will come to a stop. Neither the starter motor or starter rope will be able to turn over the motor. To free the small rock, remove the six lock nuts attaching the water intake, and then free the rock or obstruction that is wedged between the impeller and housing.

Your jet drive is equipped with a shear key to protect the unit in the event of a rock jam. See [page 7](#) for shear key replacement.

Intake Blockage

Occasionally, when either holding or proceeding slowly upstream in a fast moving shallow area, you will lose power. This is usually caused by suction holding larger flat rocks, lily pads, or debris against the intake grille and restricting the water intake. This problem can be resolved by quickly stopping the motor and then restarting it, the rocks or debris will fall away from the water intake and full power will be restored.

However, if a rock or debris is jammed in between the intake grille bars, it must be removed by prying it out of the grille with an appropriate tool, such as a screwdriver.

Mooring

If your boat is tied up by the seashore where the action of surf causes the boat to rise and fall on the sandy beach, be sure to tilt the outboard motor up and out of the water. If the motor is kept in the operating position, the wave action of the surf can deposit enough sand into the jet pump that the outboard motor cannot be cranked. If this happens, the jet pump will not be damaged, but it will need to be washed out before attempting to start the motor.

Throttle Control

As with any outboard, you will get maximum mileage by not running at full throttle. You should also not run at one third to half throttle with the boat at a steep angle, which leaves a large wake and wastes fuel.

Run at a slow idle speed for trolling and moving cautiously in uncharted areas. Running at half speed and a steep angle is the most vulnerable position for hull damage with submerged obstructions.

For cruising, run at the least throttle that will maintain an easy plane (not a sluggish one). Go to full throttle only when necessary for minimum draft, climbing steep drop offs, or starting a heavy load.

When planing easily, you will slide over most any obstruction that is just below the water surface, out of sight, and not leave a telltale disturbance on the surface of the water.

Reducing Spray and Cavitation

An intake fin kit is available to reduce cavitation when running with the wind in a chop. The intake fin kit attaches to the intake assembly and directs more water into the impeller. To purchase the intake fin kit, contact an authorized Honda Marine dealer.

To further reduce spray, or reduce cavitation in rough water, a 1/32" thick galvanized splash plate can be used. This will allow mounting the motor higher to reduce drag. This splash plate must be custom fabricated for an individual boat and fastened to the hull using a wooden block and screws. Since the splash plate must be built for a specific boat and hull, it is not available off-the-shelf through a Honda Marine dealer. Contact an authorized Honda Marine dealer for more information.

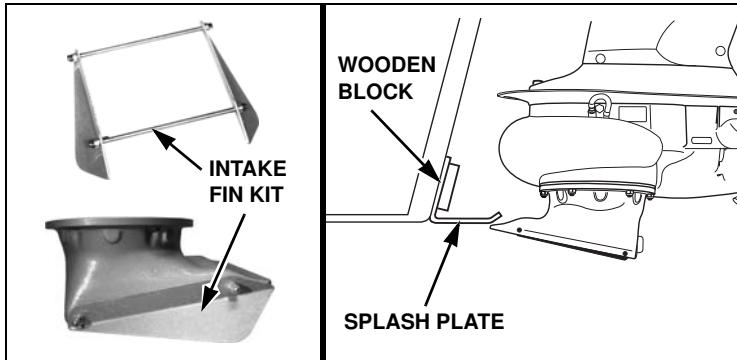

SERVICING YOUR JET DRIVE

Proper maintenance is essential for safe, economical, and trouble-free operation.

⚠ WARNING

Improper maintenance, or failure to correct a problem before operation, can cause a serious malfunction. Some malfunctions can seriously hurt or kill you. Always follow the inspection and maintenance procedures in this owner's manual.

To help you properly care for your jet driven outboard, the following pages include simple maintenance and inspection procedures using basic hand tools. Other service tasks that are more difficult or require special tools are best handled by professionals and are normally performed by a Honda Marine technician or other qualified mechanic.

Remember that an authorized Honda Marine servicing dealer knows your outboard best and is fully equipped to maintain and repair it. To ensure the best quality and reliability, use only new, Honda Genuine parts or their equivalents for repair and replacement.

Maintenance Safety

Some of the most important safety precautions follow. However, we cannot warn you of every conceivable hazard that can arise in performing maintenance. Only you can decide whether or not you should perform a given task.

⚠ WARNING

Improper maintenance can cause an unsafe condition. Failure to properly follow maintenance instructions and precautions can cause you to be seriously hurt or killed. Always follow the procedures and precautions in this manual.

Safety Precautions

Make sure the engine is off before you begin any maintenance or repairs. This will eliminate several potential hazards:

- **Carbon monoxide poisoning from engine exhaust**
Be sure there is adequate ventilation whenever you operate the engine.
- **Burns from hot parts**
Let the engine and exhaust system cool before touching.
- **Injury from moving parts**
Do not run the engine unless instructed to do so.

Read the instructions before you begin, and make sure you have the tools and skills required.

To reduce the possibility of fire or explosion, be careful when working around gasoline. Use only a nonflammable solvent, not gasoline, to clean parts. Keep cigarettes, sparks, and flames away from all fuel-related parts.

Maintenance Schedule

Item ¹	Interval	Page
General Inspection	• Inspect the jet drive unit's hardware occasionally	page 6
Bearing Lubrication	• Lubricate the bearing after each use or every 10 hours • Every 30 to 40 hours, pump additional grease through the bearing to purge any moisture	page 6
Reverse Gate Linkage	• Occasionally inspect the reverse gate's operation and hardware	page 6
Salt Water Use	• Occasionally inspect hardware for corrosion or salt buildup • Remove and reinstall all hardware every year to prevent it from seizing, corroding, or rusting ²	page 6
Impeller	• Occasionally inspect the impeller for wear or damage ²	page 6

1: For commercial use, log hours of operation to determine the proper maintenance intervals

2: This item should be serviced by an authorized Honda Marine servicing dealer unless you have the proper tools and are mechanically proficient.

Failure to follow this maintenance schedule could result in non-warrantable failures.

General Inspection

Check all mounting bolts, screws, and linkage connections occasionally to be sure they are tight.

Bearing Lubrication

Grease the bearing every 10 hours.

A tube of grease is supplied with your jet drive. Make greasing a part of your cleanup after the day's use.

Disconnect the lube hose from the zerk grease fitting, and then pump in just enough grease to replace the grease that is already in the lube hose. Reconnect the lube hose coupling to the zerk grease fitting.

Every 30 to 40 hours, pump in extra grease to purge any moisture from the bearing. The texture of the grease coming out gives an indication of conditions inside the bearing housing. A gradual increase in moisture content over time indicates seal wear.

If the grease begins to turn a dark, dirty gray, the bearing and seals should be inspected, and replaced if necessary. Some discoloration of the grease is normal during the break-in period when the bearing and seals are new.

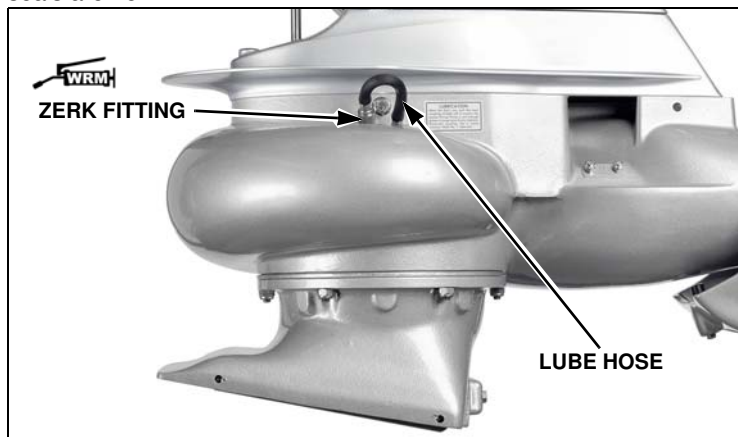

Reverse Gate Linkage

Occasionally, check the adjustment of the reverse gate linkage. In FORWARD, the gate should be firmly locked in position. Pull on the gate to verify that it does not move. This will prevent wave action from accidentally shifting the gate into reverse as the boat is violently maneuvered.

The roller should be at the end of the slot in the cam so that the gate cannot be forcibly rotated toward reverse. Do not be concerned if the gate does not fully close in the reverse position, as water pressure will close it.

If improperly adjusted, the reverse gate can be tripped into reverse when not expected, and will cause the outboard motor to kick up out of the water.

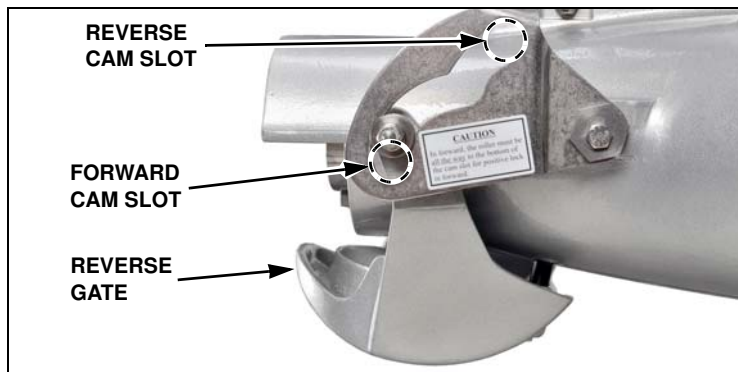

Salt Water Use

Aluminum and stainless steel have been used in the construction of your jet drive. These materials have either been treated or are inherently resistant to corrosion. When not in use, it is recommended that the outboard motor should be tilted up so the jet unit is out of the water.

When used in salt water more than fresh water, remove the mounting hardware, clean and regrease using water resistant marine grease, and then reassemble once per year. Failure to do so may result in hardware that is difficult, if not impossible, to remove at a later date.

Impeller

Inspection

Occasionally, inspect the impeller's leading edges and the impeller clearance using the following *Leading Edge Inspection* and *Impeller Clearance* procedures.

Remove the intake assembly and flanged liner to gain access to the impeller, as shown below. Installation of the intake assembly and flanged liner is the reverse order of removal. Add water resistant marine grease to the stud threads before reinstalling the 5/16"-18 lock nuts.

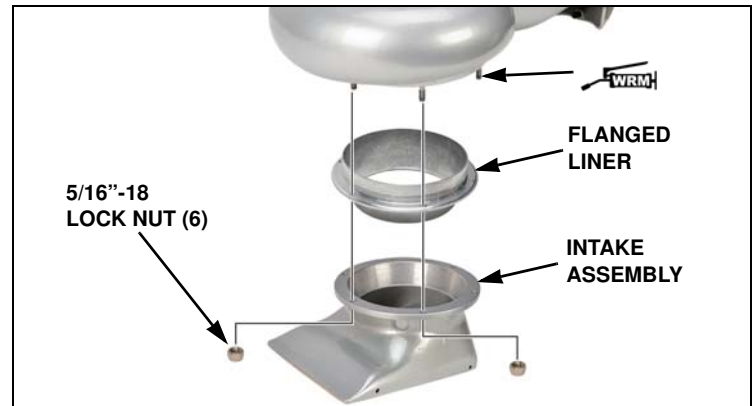

Leading Edge Inspection

Inspect the impeller for damage or rounded leading edges that are caused by the ingestion of gravel. For maximum performance, file the impeller's leading edges to keep them as sharp as when new.

1. File along the slope on the upper side of the blades.
2. File along the underside of each blade until the leading edge is 1/32" (0.79 mm). Do **not** bevel the leading edge of the blades to create a knife-like edge.
3. Blend the underside of the blade in a gentle curve.

Rough edges on the impeller can cause decreased performance and cavitation. Cavitation occurs in low pressure areas around the rough edges of the impeller blades, and can cause small pockets of water to boil, which creates steam. The small pockets of steam will then collapse and release a large amount of energy that prematurely erodes the impeller.

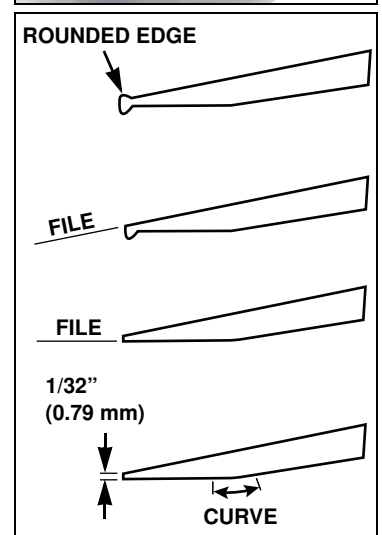
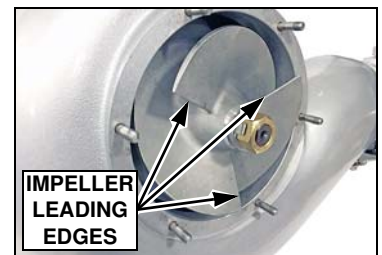

Impeller Clearance

As the impeller wears during normal usage, the clearance between the impeller and the flanged liner becomes larger.

For optimal performance, the impeller clearance should be $1/32"$ (0.79 mm). Use a feeler gauge to measure the gap between the impeller blades and the flanged liner. Hold the flanged liner in place while measuring. Be sure to measure the gap for all three blades before determining the impeller clearance.

Remove the brass nut, nut keeper, cup, and urethane washers, impeller shims, and the impeller. Stack additional shims onto the top side of the impeller until the impeller clearance has been corrected. Place any remaining shims on the bottom side of the impeller.

Once there are no shims left underneath the impeller and the impeller clearance is still excessive, replacement of the impeller will be required.

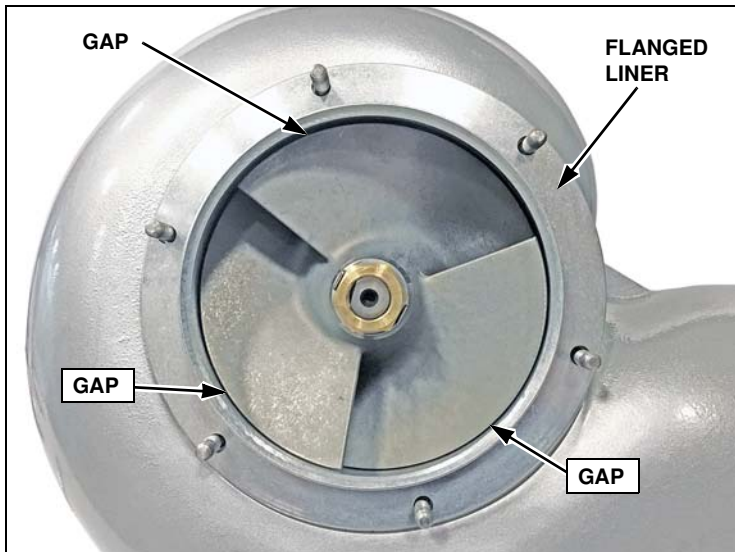
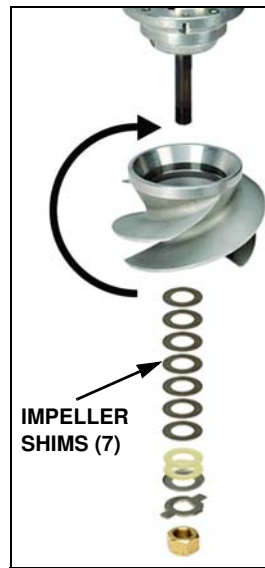

The flanged liner may have gouging from gravel. This is normal, and there is considerable surface on the liner for wear. If the impeller has been replaced and the blade clearance is still more than $1/32"$ (0.79 mm) with all seven shims beneath the impeller, the flanged liner may need to be replaced.

Be sure to grease the driveshaft mating surface, the shear key, sleeve, and driveshaft threads during reassembly. See [page 11](#) for impeller installation.

Shear Key Replacement

Your jet driven outboard is equipped with a shear key to protect the components in the event of a rock jamming in between the impeller and the intake housing.

The shear key can be removed and replaced by following the procedure below. Note the number and positions of the impeller shim washers relative to the impeller, and replace them in the same order.

If you experience difficulty removing the impeller, it is most likely due to the shear key being wedged against the side of the driveshaft.



1. Remove the intake assembly and flanged liner by loosening the six $5/16"$ -18 lock nuts.

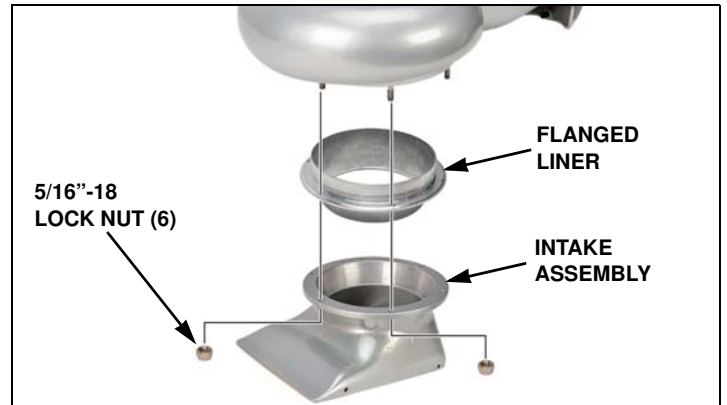

2. Remove the following:

- Brass nut
- Nut keeper
- Cup
- Urethane washers (2)
- Impeller shims
- Impeller

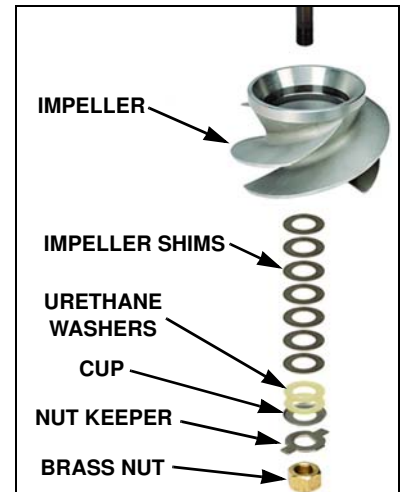

3. Remove the shear key from the impeller.

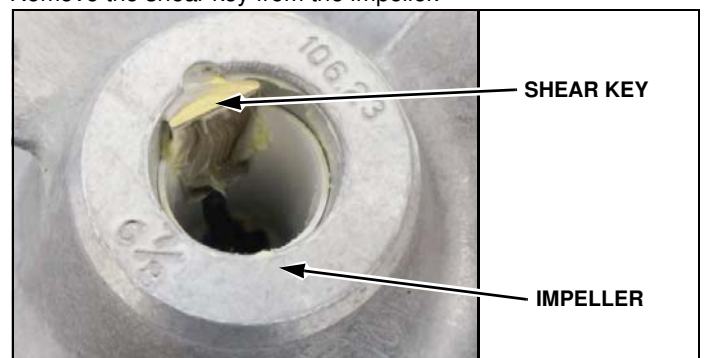

4. Replace the shear key, and then reinstall the impeller, flanged liner, and intake assembly in the reverse order of removal. Use a new nut keeper when reinstalling the impeller. Refer to [page 11](#) for more detail.

JET DRIVE ASSEMBLY

List of Parts

The jet drive unit comes partially assembled. The items listed in the table below are the assemblies and individual parts that are included in the jet drive unit's box.

A genuine Honda BF150A water pump kit (P/N 16193-ZY6-A01) is supplied with the jet drive unit and should be installed during assembly.

For a complete list of individual parts for the jet drive unit, refer to the information found in the Parts Catalog (page 14).

Ref.	Item	Qty.
1	Neutral cable assembly	1
2	Honda water pump kit	1
3	Driveshaft assembly	1
4	Grease, tube	1
5	Main housing assembly	1
6	Adapter plate	1
7	Impeller	1
8	3/16" x 1/2" dowel pin	2
9	6 x 10 mm dowel pin	4
10	Shift rod guide	1
11	Shear key (includes one spare)	2
12	Sleeve shaft (plastic) (includes one spare)	2
13	Flanged liner	1
14	5/16"-18 lock nut	6
15	Intake assembly	1
16	10 x 35 mm hex bolt	5
17	3/8"-16 x 1-1/2" hex bolt	1
18	3/8"-16 x 2-1/4" hex bolt	2
19	10 x 90 mm hex bolt	1
20	10 x 100 mm hex bolt	1
21	3/4"-16 shaft nut (brass)	1
22	Nut keeper (includes one spare)	2
23	10 mm lock washer	10
24	Cup (torsional damper)	1
25	Urethane washer (torsional damper)	2
26	5/16"-18 x 1" hex bolt	4
27	5/16" lock washer	4
28	Shim washers	7

Parts Diagram



Assembly

1. Secure the engine on a stand or on the boat's transom so that it is mounted vertically.
2. Install the jet drive driveshaft assembly into the main housing using the four 5/16"-18 x 1" hex bolts and 5/16" lock washers, in the orientation shown. Make sure driveshaft assembly is positioned so that the two small O-rings on the driveshaft align with the two corresponding grease holes in the main housing. Grease the bolt threads prior to installation, and then tighten to the specified torque.

TORQUE: 15 lbf-ft (20 N·m)

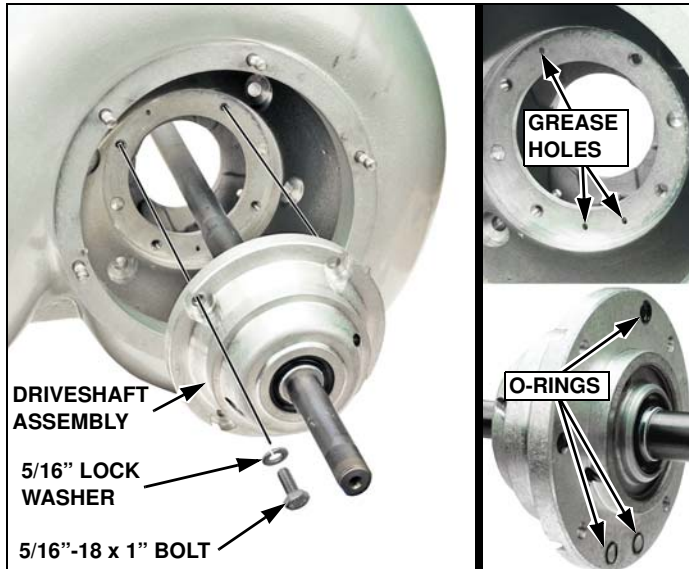

3. Install the water pump assembly onto the main housing using the following procedure:

- a. Insert two 6 x 10 mm dowel pins into the main housing.

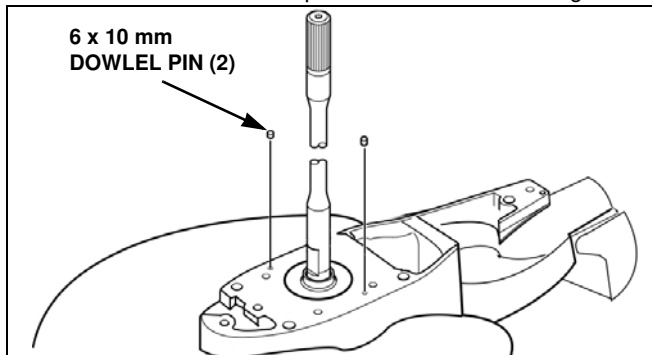

- b. Place the water pump gasket and impeller cover on top of the main housing by sliding them down over the top of the driveshaft, in the orientation shown. Make sure the dowel pin holes in gasket and cover fit over the 6 x 10 mm dowel pins.

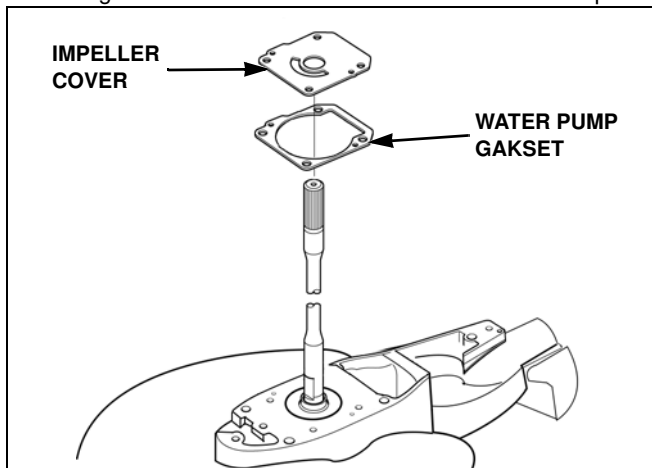

- c. Install the pump liner into the impeller housing by aligning the projections on the pump liner with the cavities inside the impeller housing.

Apply water resistant marine grease to the inner wall of the pump liner.

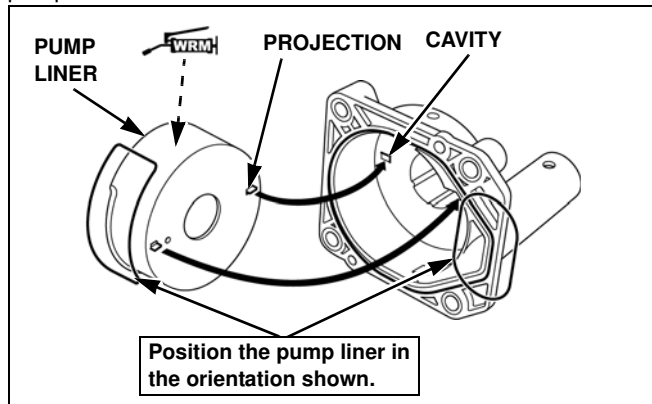

- d. Apply water resistant marine grease to the circumference of a new water pump O-ring, and then install it into the impeller housing.

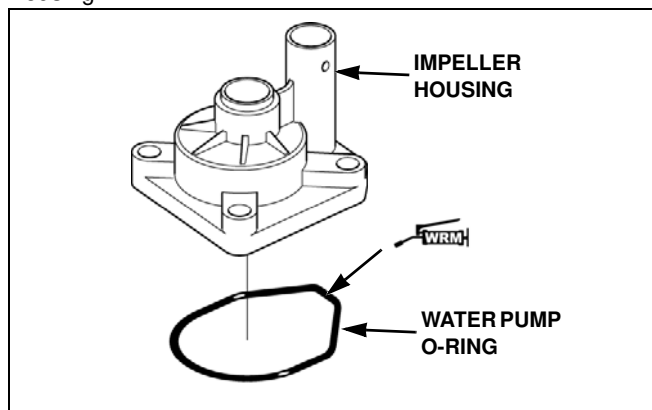

- e. Set the water pump special key (found in the water pump kit) in the flat area on the driveshaft, and then slide the rubber pump impeller down the driveshaft and align the notch in the impeller with the special key.

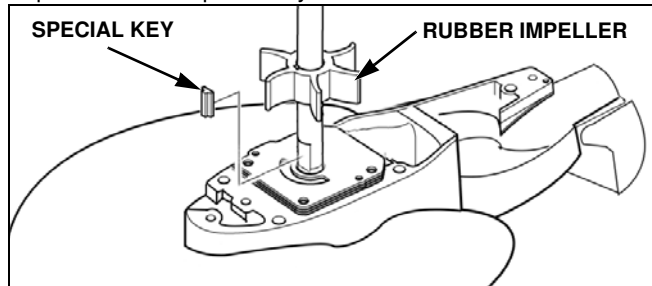

- f. Install the impeller housing assembly by sliding it down over the driveshaft. Rotate the driveshaft clockwise (when looking down over the main housing) when mating the impeller housing assembly around the rubber impeller and onto the impeller cover. Doing this will set the rubber impeller fins in the correct direction.

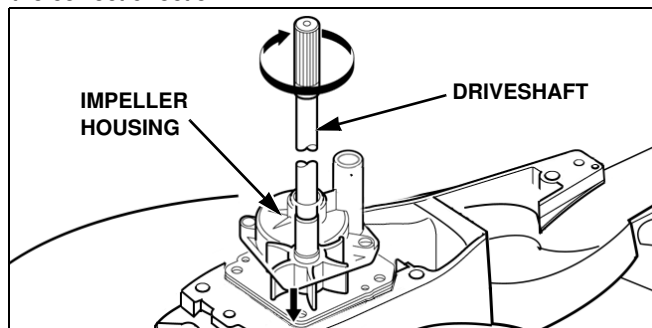

- g. Install the four distance collars and 8 x 40 mm bolts/washers. Apply water resistant marine grease to the bolt threads, and then tighten to the specified torque.

TORQUE: 15 lbf-ft (20 N·m)

Place the water tube seal ring into the impeller housing by aligning the projection on the seal with the hole in the housing, and then grease the inner wall of the seal ring.

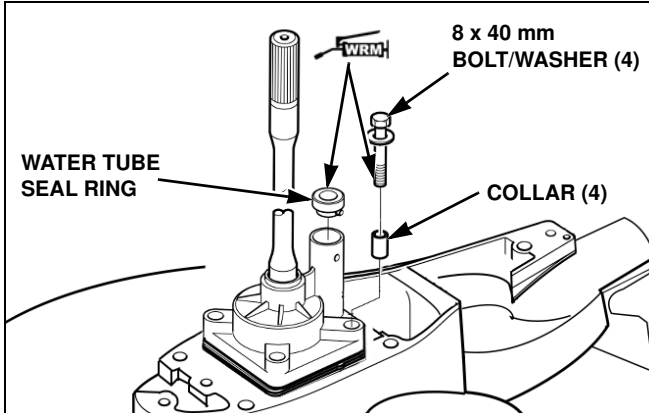

4. Insert the shift rod guide and two 6 x 10 mm dowel pins into the appropriate holes in the adapter plate as shown. Apply water resistant marine grease to the upper half of the shift rod guide.

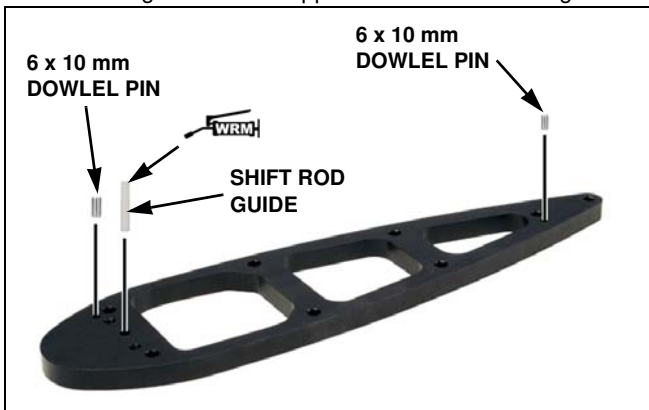

5. Install the adapter plate onto the bottom of the outboard's extension case using the five 10 x 35 mm hex bolts and 10 mm lock washers. Grease the bolt threads prior to installing the bolts. Tighten the five hex bolts to the specified torque.

TORQUE: 22 lbf-ft (29 N·m)

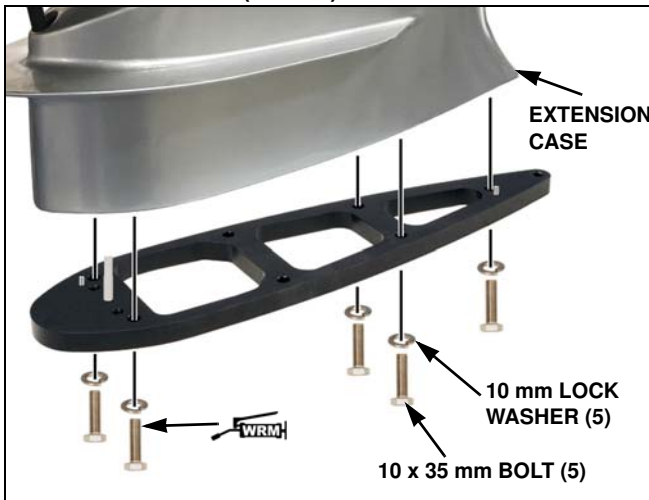

6. Attach the jet drive to the extension case using the following procedure.

- a. Install the two 3/16" x 1/2" dowel pins into the main housing as shown.

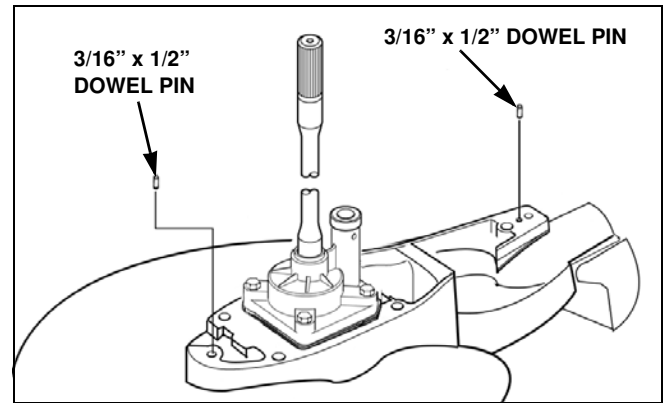

- b. Use the two 3/8"-16 x 2-1/4" bolts, 10 x 90 mm bolt, 10 x 100 mm bolt, and four lock washers to secure the jet drive assembly to the extension case. Grease the bolt threads and the upper driveshaft splines prior to guiding the jet drive into place. The 3/8"-16 x 2-1/4" bolts should be installed in the holes at the front end of the main housing. The 10 x 90 mm bolt should be installed in the port-side rear hole. The 10 x 100 mm bolt should be installed in the starboard-side rear hole.

TORQUE: 22 lbf-ft (29 N·m)

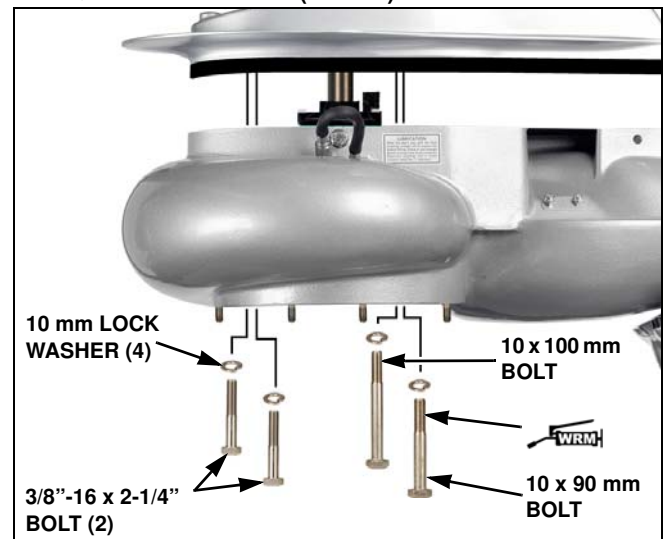

7. Install the 3/8"-16 x 1-1/2" hex bolt and a 10 mm lock washer through the adapter plate and into the main housing, as shown. Tighten the bolt to the following torque.

TORQUE: 22 lbf-ft (29 N·m)

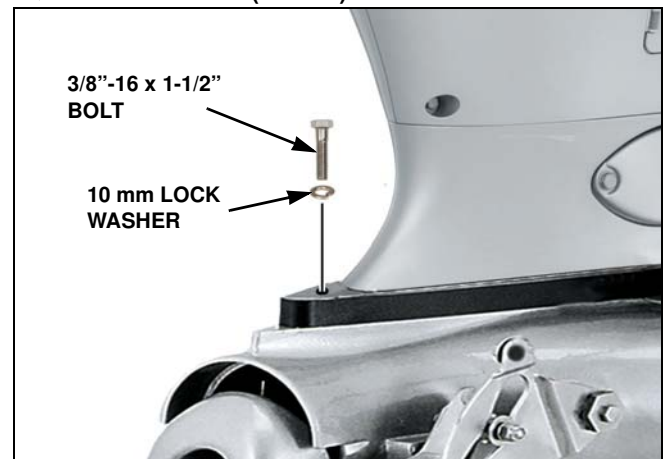

8. Install the jet drive impeller onto the driveshaft using the following procedure.

- a. Apply water resistant marine grease to the vertical shaft threads of the driveshaft, shear key, and impeller bore.

Slide the shear key into the impeller bore slot, and then place one plastic shaft sleeve inside the impeller bore. Align the slit in the shaft sleeve with the shear key.

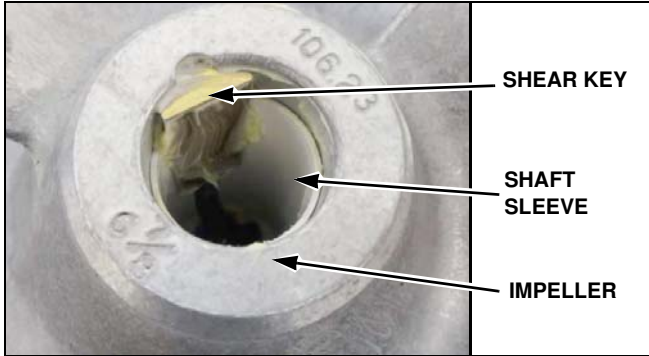

Hold the shear key in the slot in the impeller with your finger, and then slide the impeller onto the driveshaft.

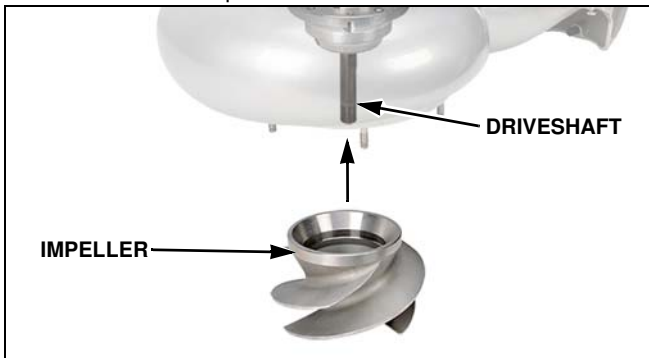

- b. Install the seven shim washers, one urethane washer, cup, one nut keeper, and brass nut onto the vertical shaft up against the impeller and secure by hand. Tighten the brass nut within the specified torque range, until the ears of the nut keeper are aligned with the flats on the brass nut.

TORQUE:
4 – 22 lbf-ft (5 – 30 N•m)

Note:

Shims should not be placed above the impeller on new installations where no wear has occurred, unless the blade clearance exceeds 1/32". Insufficient blade clearance will do more harm than good from any performance gains it might provide.

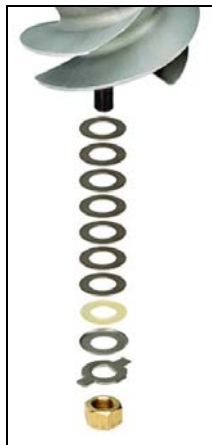

- c. Fold the washer retainer tabs down against the nut to retain it. If the ears of the nut keeper do not line up with the flats on the brass nut, remove the nut, turn the nut keeper over, and then retighten the brass nut.

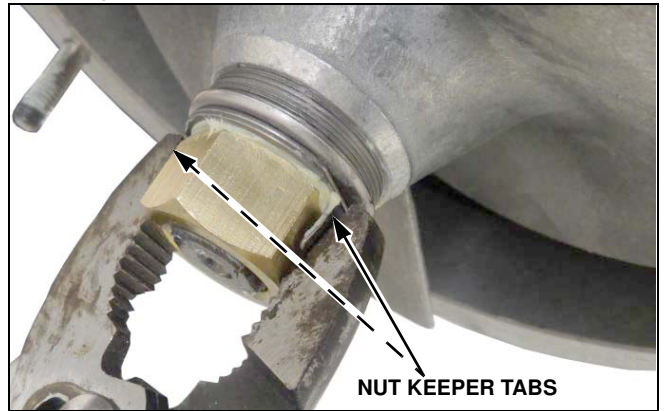

9. Install the flanged liner and intake assembly in position with the lower end of the intake toward the rear. Grease the stud threads and tighten the six 5/16"-18 lock nuts to the specified torque. Do not use lock washers.

TORQUE: 15 lbf-ft (20 N•m)

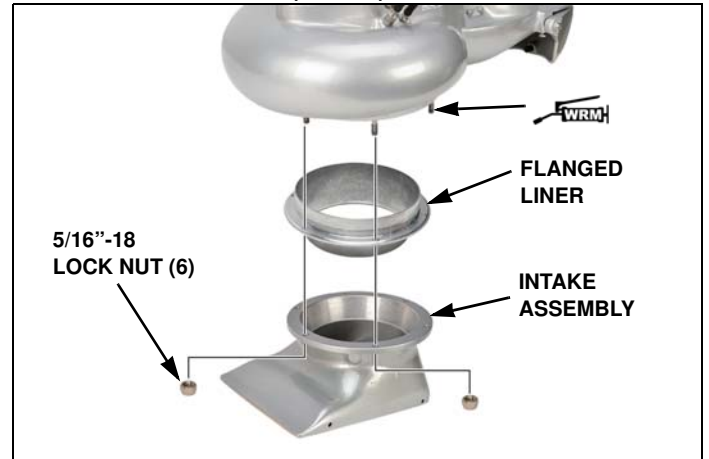

10. See "INSTALLATION & RIGGING" on page 12 for transom mounting and rigging instructions.

INSTALLATION & RIGGING

Remote Controls

A shift cable assembly and neutral cable assembly (provided with the jet drive unit) will be used for remote control operation. The shift cable is moved by the remote control box and operates the reverse gate. The neutral cable operates forward, neutral, reverse, and neutral safety switch functions inside the outboard motor.

The shift cable is attached to the cable anchor bracket and reverse gate linkage. This cable is routed over the transom and connects to the remote control box. The neutral cable attaches to the reverse gate linkage and cable anchor bracket, and is routed between the outboard and transom bracket, around the front of the outboard, through the cable grommet, and then attaches to the shift link pin. The neutral cable must be routed this way to prevent kinking the cable.

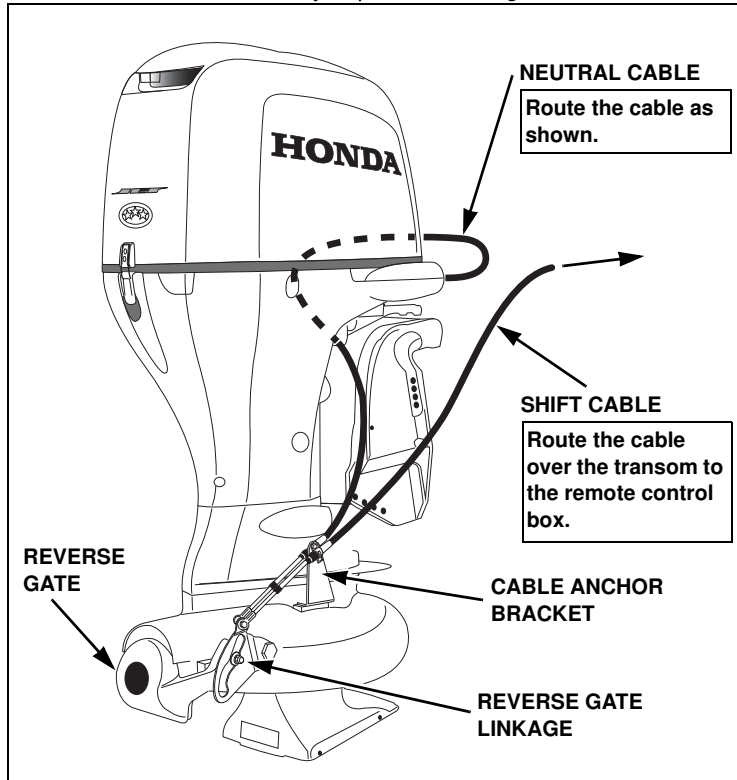

With the remote control's shift handle in forward, the reverse gate linkage in forward, and the cam roller at the end of the slot, attach the shift cable to the **outer side** of the reverse gate linkage on the jet drive. Adjust the cable and/or cable anchor bracket position to this set condition. Shift to reverse, and then back to forward. The roller should be at the end of the cam slot so that the gate cannot be forcibly rotated toward reverse. Pull on the gate by hand to verify this. If this forward lock condition is not met, make the necessary adjustments to the shift cable so that the reverse gate linkage positions are correct.

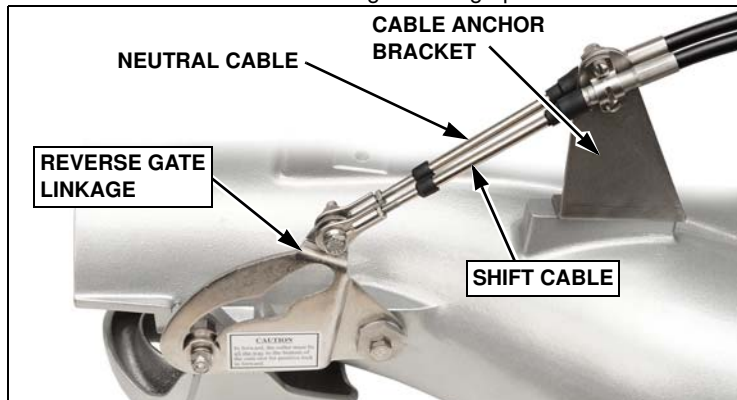

Attach the neutral cable to the reverse gate linkage and onto the **inner side** of the cable anchor bracket. Adjust the neutral cable's end link so that the number of threads shown match the number of threads shown on the shift cable's end link. The neutral cable should act as an extension of the shift cable.

After the neutral cable is attached to the reverse gate linkage and to the **inner side** of the cable anchor bracket, it must be routed between the outboard motor and transom bracket and toward the port side of the outboard. The neutral cable should then pass around the front of the outboard, through the rigging grommet, and attached to the shift link pin on the outboard.

Move the shift link pin to the FORWARD direction.

Adjust the shift pivot assembly/cable so that it easily slides over the shift link pin without any help or force. It is very important that the neutral cable is adjusted properly to ensure the neutral safety switch functions correctly.

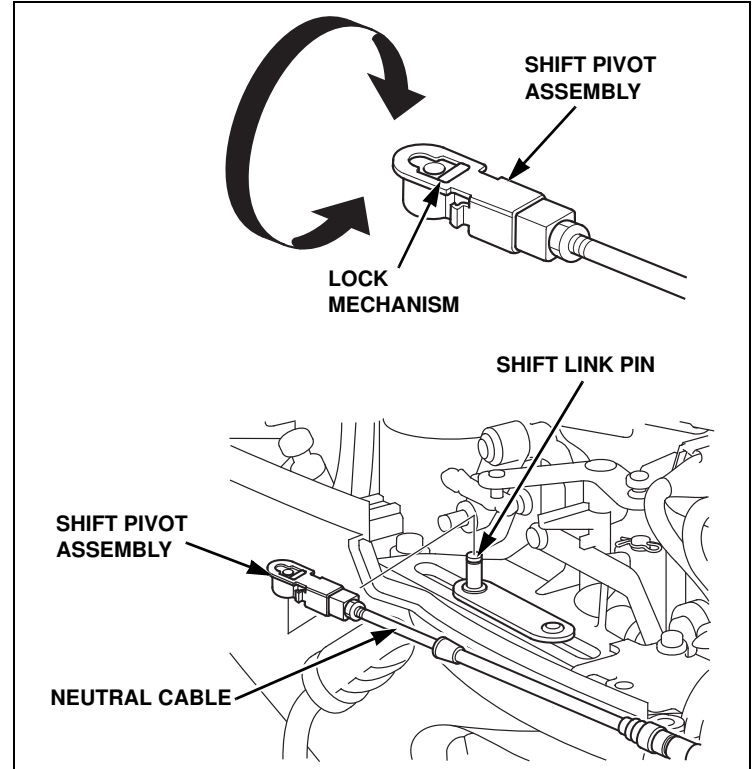

Outboard Mounting

When mounting the outboard motor onto the boat transom, the motor will have to be positioned to the height shown the image below using a straight edge under the boat. The bottom of the boat that is just in front of the jet drive intake should be level with the leading edge of the intake.

The outboard motor transom bracket has four sets of upper mounting holes. You will use one set to begin with. Mark pencil lines on the boat transom through the other sets of holes. Then, if you wish to go up or down 3/8", you can drill one alternate set of holes 3/8" up or down from the pencil marks. By alternating between these two sets of transom holes and the four sets of motor holes, the motor can be moved in 3/8" increments over almost one inch.

If you raise the motor too much, it will suck air and cavitate during start up or when banking on turns. When cavitating, the motor over speeds in spurs and shakes considerably in the motor mount. This is not a normal condition and should be avoided by proper adjustment of the motor height on each individual boat. If you lower the motor too much, you will have excessive drag. Therefore, mount the motor as high as possible without allowing cavitation.

Test run the boat, and then raise or lower the motor 3/8" at a time to obtain the best results.

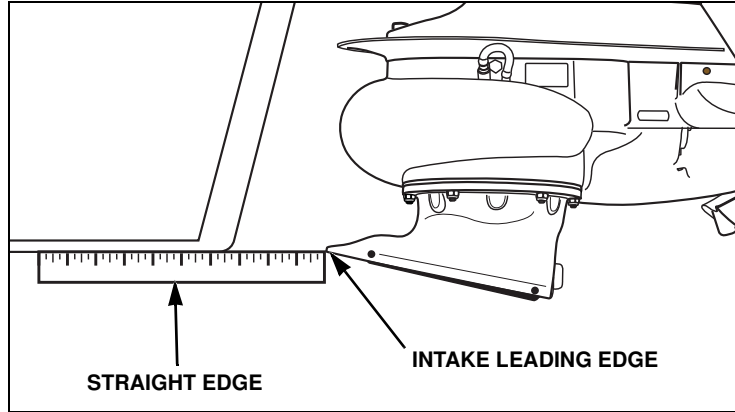

TROUBLESHOOTING

The possible causes listed are issues that may arise from the jet drive unit, and assumes the outboard motor (engine) is working properly.

Poor performance

Possible Cause	Correction
Clogged jet intake	<ul style="list-style-type: none"> Inspect and remove obstructions that may be blocking the intake, such as leaves, sticks, or gravel (page 4).
Worn or damaged impeller	<ul style="list-style-type: none"> Inspect the impeller for wear or damage (page 6). Inspect the impeller clearance, and ensure it is within specification (page 6). Inspect the flanged liner for damage (page 6).
Incorrect outboard mounting height	<ul style="list-style-type: none"> Inspect the outboard mounting height, and ensure the jet drive intake is set at the appropriate height (page 13).
Jet drive unit ingesting air (cavitation)	<ul style="list-style-type: none"> Confirm the hull design of the boat is compatible with a jet drive outboard (page 3). Inspect the outboard mounting height, and ensure the jet drive intake is set at the appropriate height (page 13). Install a splash plate between the boat transom and jet drive intake (page 5).
Shear key broken	<ul style="list-style-type: none"> Inspect the shear key for damage, and replace if broken (page 7).
Reverse gate incorrectly adjusted	<ul style="list-style-type: none"> Inspect the reverse gate linkage, and ensure it is properly adjusted, and that it has not been damaged (page 6).
Boat or jet intake not in water.	<ul style="list-style-type: none"> Ensure the jet drive intake is under water. Ensure boat is not beached or sitting on the river bottom.

Outboard propels while in neutral

Possible Cause	Correction
Reverse gate improperly adjusted	<p>The jet unit will always provide a small amount of thrust while the engine is idling.</p> <p>Adjust the reverse gate linkage cable(s) in the appropriate direction until the boat remains stationary, or as close to stationary as possible while in neutral.</p> <p>A small amount of forward movement is typically desired over reverse movement.</p>

TECHNICAL INFORMATION

Serial Number Location



The serial number for the jet drive is located on the port side of the jet pump housing. Record the serial number in the space below. You will need this serial number when ordering parts and when making technical or warranty inquiries.

Jet drive serial number: _____

Date of purchase: _____

CUSTOMER INFORMATION

Register Your Jet Drive Outboard

Please take a few minutes and register your purchase with Honda. Only the outboard motor frame serial number needs to be registered. The serial number shown on the jet drive unit does not need to be registered. You can register by:

- Going to marine.honda.com and clicking on Product Registration
- Scanning this QR code.



Parts and Service Items

Contact an authorized Honda Marine servicing dealer to purchase replacement parts, accessories, or other Honda Genuine items for your jet drive outboard.

Dealer Locator Information

To find an authorized Honda Marine servicing dealer anywhere in the United States:

Visit marine.honda.com and click on Find a Dealer.

How to Contact Honda

Honda Marine dealership personnel are trained professionals. They should be able to answer any question you may have. If you

encounter a problem that your dealer does not solve to your satisfaction, please discuss it with the dealership's management. The Service Manager or General Manager can help. Almost all problems are solved in this way.

If you are dissatisfied with the decision made by the dealership's management, contact the Honda Marine Customer Relations Office. You can write:

American Honda Motor Co., Inc.
Marine Division
Customer Relations Office
4900 Marconi Drive
Alpharetta, GA 30005-8847

Or telephone: (770) 497-6400 M-F, 8:30 a.m. - 7:00 p.m. ET

When you write or call, please give us this information.

- Model and serial number ([page 14](#))
- Name of the dealer who sold the outboard to you
- Name and address of the dealer who services your outboard
- Date of purchase
- Your name, address, and telephone number
- A detailed description of the problem

Honda Publications

These publications will give you information for maintaining and repairing your jet drive outboard.

Owner's Manual

Keep this owner's manual handy so you can refer to it at any time. Consider this owner's manual a permanent part of the outboard; please give it to the new owner if you resell the outboard.

The information and specifications included in this publication were in effect at the time of approval for printing. American Honda Motor Co., Inc. reserves the right, however, to discontinue or change specifications or design at any time without notice and without incurring any obligation whatever. No part of this publication may be reproduced without written permission.

Shop Manual

This manual covers complete maintenance and overhaul procedures. It is intended to be used by a skilled technician. Available through your Honda Marine dealer or visit marine.honda.com and click on Service & Support; then click on Shop Manuals.

Parts Catalog

This manual provides complete, illustrated parts lists, and is available through your Honda Marine dealer.

Frequently Asked Questions



The Honda Marine web site provides additional information for users of Honda Marine products. Visit marine.honda.com and click on FAQs or scan the QR code shown.

DISTRIBUTOR'S LIMITED WARRANTY

Honda Outboard Motors

This warranty is limited to Honda Outboard Motors and related original equipment distributed by American Honda Motor Co., Inc., Power Equipment Division, 4900 Marconi Drive, Alpharetta, Georgia 30005-8847.

Products Covered by Warranty:	Length of Warranty: (from date of original retail purchase)		
	NON-COMMERCIAL/ NON-RENTAL	COMMERCIAL/ RENTAL	STATE/LOCAL/ FEDERAL GOVERNMENT
All models purchased on or after Jan. 1, 2016 ⁽²⁾	60 months	24 months	36 months
All models purchased between July 1, 2008 and December 31, 2015 ⁽²⁾	60 months	12 months	24 months
All models purchased on or before June 30, 2008 ⁽¹⁾⁽²⁾	36 months	12 months	24 months
Related original equipment items: BF5 through BF20 models: Portable fuel tank and original propeller. All models: Primer bulb/fuel line assembly and tiller handle.	The same duration as the outboard with which they were purchased. ⁽³⁾		

(1) Models purchased prior to July 1, 2008 (unless previously purchased with True-5 warranty from a participating dealer).

(2) 40, 65, & 105 Jet models: Jet pump assembly is a dealer installed option. Jet pump warranty is provided by Specialty Manufacturing Co. (Outboard Jets).

(3) Portable fuel tanks: 24 months or the same duration as the outboard they were purchased with, whichever is longer.

To Qualify for This Warranty:

The Honda Outboard Motor must be purchased from American Honda or a dealer authorized by American Honda to sell Honda Outboard Motors in the United States, Puerto Rico, or the U.S. Virgin Islands. This limited warranty applies to the first retail purchaser and each subsequent owner during the applicable warranty time period.

What American Honda Will Repair or Replace Under Warranty:

American Honda will repair or replace, at its option, any part that is proven to be defective in material or workmanship under normal use during the applicable warranty time period. Warranty repairs and replacements will be made without charge for parts or labor. Anything replaced under warranty becomes the property of American Honda Motor Co., Inc. All parts replaced under warranty will be considered as part of the original product and any warranty on those parts will expire coincidentally with the original product warranty.

To Obtain Warranty Service:

You must, at your expense, take your Honda Outboard Motor and proof of the original purchase date to any dealer who is authorized to service Honda Outboard Motors in the United States, Puerto Rico, or the U.S. Virgin Islands, during the dealer's normal business hours. If you are unable to obtain warranty service, or are dissatisfied with the warranty service you receive, take the following steps: First, contact the owner of the dealership involved; normally this should resolve the problem. However, if you should require further assistance, write or call the Honda Marine Customer Relations Department of American Honda Motor Co., Inc.

American Honda Motor Co., Inc.
Honda Marine Customer Relations Department
4900 Marconi Drive
Alpharetta, Georgia 30005-8847
Telephone: (770) 497-6400

Exclusions:

This warranty does not extend to the following:

- Conditions caused by lack of routine maintenance or improper storage (as outlined in the owner's manual)
- Conditions caused by the use of propeller(s) that do not allow the outboard motor to run in its recommended full throttle rpm range
- Operation inconsistent with the recommended operation/duty cycle (as outlined in the owner's manual)
- Parts affected or damaged by an abuse, submersion and/or collision
- Fuel contamination and water entering the engine through the fuel intake, air intake, or exhaust system
- Operation with fuels, oils, additives and lubricants which are not suitable for use in the product
- Use in an application for which the outboard motor was not designed, such as racing or competitive use or any other misuse or neglect
- Normal wear and tear
- Incorporation of unsuitable attachments or parts
- The unauthorized alteration, improper installation and/or rigging, or any causes other than defects in material or workmanship
- Corrosion to steering system or electrical components, corrosion due to electrolysis, water born foreign chemicals, improper service or corrosion caused by damage or abuse
- Reimbursement for towing charges, in and out of water charges, or technician travel time
- Growth of marine organisms on motor surfaces, external or internal
- Any product that has ever been declared a total loss or sold for salvage by a financial institution or insurer, or that has been issued a "salvage" or similar title under any state's law.

Disclaimer of consequential damage and limitation of implied warranties:

American Honda disclaims any responsibility for loss of time or use of the outboard, revenue, or the equipment in which the outboard is installed, transportation, commercial loss, or any other incidental or consequential damage. Any implied warranties are limited to the duration of this written limited warranty.

Some states do not allow limitations on how long an implied warranty lasts and/or do not allow the exclusion or limitation of incidental or consequential damages, so the above exclusions and limitations may not apply to you. This warranty gives you specific legal rights, and you may also have other rights which vary from state to state.

Accessories and Replacement Parts

This warranty is limited to Honda Marine parts, accessories and apparel when distributed by American Honda Motor Co., Inc., 1919 Torrance Blvd., Torrance, California 90501-2746.

Products Covered by Warranty:	Length of Warranty: (from date of original retail purchase)		
	NON-COMMERCIAL	COMMERCIAL/RENTAL	STATE/LOCAL/ FEDERAL GOVERNMENT
Accessories other than noted below	12 months	3 months	3 months
Emission related accessories: Portable fuel tanks, fuel line assemblies, and water/fuel separators	24 months	24 months	24 months
Replacement Parts	6 months	3 months	3 months

To Qualify for This Warranty:

1. The accessories or replacement parts must be purchased from American Honda or a dealer, distributor, or distributor's dealer authorized by American Honda to sell those products in the United States, Puerto Rico, and the U.S. Virgin Islands. Parts and Accessories must be purchased for installation on original Honda equipment or engines to be eligible for warranty coverage. Installing Parts and Accessories on non-Honda products or engines voids this warranty.
2. You must be the first retail purchaser. This warranty is not transferable to subsequent owners.

What American Honda Will Repair or Replace Under Warranty:

American Honda will repair or replace, at its option, any marine product accessories or replacement parts that are proven to be defective in material or workmanship under normal use during the applicable warranty time period. Anything replaced under warranty becomes the property of American Honda Motor Co., Inc. All parts replaced under warranty will be considered as part of the original product and any warranty on those parts will expire coincidentally with the original product warranty.

Accessories and replacement parts, installed by a dealer who is authorized by American Honda to sell them, will be repaired or replaced under warranty without charge for parts or labor. If installed by anyone else, accessories and replacement parts will be repaired or replaced under warranty without charge for parts, but any labor charges will be the responsibility of the purchaser.

To Obtain Warranty Service:

You must, at your expense, take the Honda Outboard Motor product accessory or replacement part or the outboard motor or boat on which the accessory or replacement part is installed, and proof of purchase to any Honda Marine authorized service facility or dealer in the United States, Puerto Rico, or the U.S. Virgin Islands, during normal business hours.

Exclusions:

This warranty does not extend to accessories or parts affected or damaged by collision, normal wear, use in an application for which the product was not designed or any other misuse, neglect, incorporation or use of unsuitable attachments or parts, unauthorized alteration, improper installation, or any causes other than defects in material or workmanship of the product. Installing parts and accessories on non-Honda products or engines voids this warranty.

Disclaimer of consequential damage and limitation of implied warranties:

American Honda disclaims any responsibility for loss of time or use of the outboard motor, or the boat on which the product is installed, transportation, commercial loss, or any other incidental or consequential damage. Any implied warranties are limited to the duration of this written warranty. Some states do not allow limitations on how long an implied warranty lasts and/or do not allow the exclusion or limitation of incidental or consequential damages, so the above exclusions and limitations may not apply to you.

This warranty gives you specific legal rights, and you may also have other rights, which vary from state to state.

EMISSION CONTROL SYSTEM WARRANTY

Your new Honda outboard engine complies with both the U.S. EPA and State of California emission regulations. American Honda provides the same emission warranty coverage for outboard engines sold in all 50 states. In all areas of the United States your outboard engine must be designed, built, and equipped to meet the U.S. EPA and California Air Resources Board emission standard for spark ignited marine engines.

CALIFORNIA EMISSION CONTROL WARRANTY STATEMENT YOUR WARRANTY RIGHTS AND OBLIGATIONS

The California Air Resources Board (CARB) and American Honda Motor Co., Inc. are pleased to explain the emission control system warranty on your 2017 Honda outboard engine. In California, new outboard engines must be designed, built, and equipped to meet the state's stringent anti-smog standards.

American Honda Motor Co., Inc. must warrant the emission control system on your outboard engine for the periods of time listed below provided there has been no abuse, neglect, or improper maintenance of your outboard engine.

Your emission control system may include parts such as the carburetor or fuel injection system, the ignition system, and catalytic converter. Also included may be hoses, belts, connectors, and other emission-related assemblies.

Where a warrantable condition exists, American Honda Motor Co., Inc. will repair your outboard engine at no cost to you including diagnosis, parts, and labor.

MANUFACTURER'S WARRANTY COVERAGE:

Select emission control parts from model year 2010 and later outboard engines are warranted for five years or 250 hours of use, whichever first occurs; or the length of the Honda Marine Distributor's Limited Warranty, whichever is longer. However, warranty coverage based on the hourly period is only permitted for engines equipped with hour meters as defined in § 2441(a)(13)* or their equivalent. If any emission-related part on your engine is defective under warranty, the part will be repaired or replaced by American Honda Motor Co., Inc.

OWNER'S WARRANTY RESPONSIBILITIES:

As the outboard engine owner, you are responsible for the performance of the required maintenance listed in your owner's manual. American Honda Motor Co., Inc. recommends that you retain all receipts covering maintenance on your outboard engine, but American Honda Motor Co., Inc. cannot deny warranty solely for the lack of receipts or your failure to ensure the performance of all scheduled maintenance.

As the outboard engine owner, you should, however, be aware that American Honda Motor Co., Inc. may deny you warranty coverage if your outboard engine or a part has failed due to abuse, neglect, improper maintenance, or unapproved modifications.

You are responsible for presenting your outboard engine to a Honda Marine dealer as soon as a problem exists. The warranty repairs will be completed in a reasonable amount of time, not to exceed 30 days.

If you have any questions regarding your warranty rights and responsibilities, you should contact

American Honda Motor Co., Inc.
Marine Division Customer Relations Office
4900 Marconi Drive
Alpharetta, Georgia 30005-8847
Telephone: (770) 497-6400

WARRANTY COVERAGE:

Honda outboard engines certified to the CARB and EPA 2010 and later regulation are covered by this warranty to be free from defects for a minimum of five years or 250 hours of operation, whichever comes first; or the length of the Honda Marine Distributor's Limited Warranty, whichever is longer, from the date of delivery to the retail purchaser. This warranty is transferred to each subsequent purchaser for the duration of the warranty period.

Warranty repairs will be made without charge for diagnosis, parts, and labor. All defective parts replaced under this warranty become the property of American Honda Motor Co., Inc. A list of warranty parts is on the adjacent column of this statement. Normal maintenance items, such as spark plugs and filters, that are on the warranted parts list are warranted up to their required replacement interval only.

American Honda Motor Co., Inc. is also liable for damages to other engine components caused by a failure of any warranted part during the warranty period. Only Honda approved replacement parts will be used in the performance of any warranty repairs, and they will be provided without charge to the owner. You may use any replacement part as defined in § 1900(b)(20)* in the performance of any maintenance or repairs. If a replacement part is used in the repair or maintenance of

your engine, and an authorized Honda Marine dealer determines it causes the failure of a warranted part, your warranty claim may be denied. If the part in question is not related to the reason that your engine requires repair, your claim will not be denied.

TO OBTAIN WARRANTY SERVICE:

You must take your Honda outboard engine, along with your sales registration card or other proof of original purchase date, at your expense, to any Honda Marine dealer that is authorized by American Honda Motor Co., Inc. to sell and service that Honda marine product during its normal business hours. Claims for repair or adjustment found to be caused solely by defects in material or workmanship will not be denied because the engine was not properly maintained and used.

If you are unable to obtain warranty service, or are dissatisfied with the warranty service you received, contact the owner of the dealership involved. Normally this should resolve your problem. However, if you require further assistance, write or call the Honda Marine Customer Relations Office of American Honda Motor Co., Inc.

EXCLUSIONS:

Failures other than those resulting from defects in material or workmanship are not covered by this warranty. This warranty does not extend to emission control systems or parts which are affected or damaged by owner abuse, neglect, improper maintenance, misuse, misfueling, improper storage, and/or collision, the incorporation of, or use of, unsuitable attachments, or the unauthorized alteration of any part.

This warranty does not cover replacement of expendable maintenance items made in connection with required maintenance service after the items first scheduled replacement as listed in the maintenance section of the product owner's manual, such as: spark plugs and filters.

DISCLAIMER OF CONSEQUENTIAL DAMAGE AND LIMITATION OF IMPLIED WARRANTIES:

American Honda Motor Co., Inc. disclaims any responsibility for incidental or consequential damages such as loss of time or the use of outboard engine, or any commercial loss due to the failure of the equipment; and any implied warranties are limited to the duration of this written warranty. This warranty is applicable only where the California or U.S. EPA emission control system warranty regulation is in effect.

EMISSION CONTROL SYSTEM WARRANTY PARTS:

SYSTEMS COVERED BY THIS WARRANTY:	PARTS DESCRIPTION:
Fuel Metering	Carburetor assembly, Throttle body, Fuel injector, Fuel pump, Fuel pressure regulator, Throttle position sensor, Intake air temperature sensor, Engine temperature sensor, Manifold absolute pressure sensor, Idle air control valve, Barometric pressure sensor, Fuel line solenoid valve, Intake manifold, Intake valves, and Oxygen sensor or Air fuel ratio sensor
Evaporative	Portable fuel tank, Fuel cap, Fuel hoses, Primer bulb, Fuel hose joint
Air Induction	Air intake duct, Vapor separator, Intake manifold tuning valve (Intake air bypass control valve)
Ignition	Flywheel magneto, Ignition pulse generator, Ignition coil assembly, Ignition control module, Engine control module, Crankshaft position sensor, Spark plug cap, Spark plug*, Knock sensor, and Camshaft position sensor
Lubrication System	Oil pump and internal parts
Crankcase Emission Control	Crankcase breather tube, Positive crankcase ventilation valve, Oil filler cap
Exhaust	Exhaust manifold and Exhaust valves
Valve Control System	Rocker arm oil control valve
Miscellaneous Parts	Tubing, fittings, seals, gaskets, and clamps associated with these listed systems.

* Covered up to the first required replacement only. See the *Maintenance Schedule* in the owner's manual.

* California Code of Regulations

NOTES

HONDA
The Power of Dreams