

OWNERS MANUAL

1. HULL SELECTION

Best performance is obtained on light, shallow draft hulls with a relatively flat, wide bottom. Hulls with deep vee or multi-vee bottom not only require more depth but also exhibit more drag when acted upon by the high line of thrust of the jet.

Aluminum is most popular due to its light weight and durability.

As a rule the bottom width should be at least 48 inches and the centerline length at least 13 feet. 6-9 degrees deadrise is good.

2. HORSEPOWER SELECTION

A boat operating at slow speed requires considerably more depth than one which is planing on the surface of the water. It is important therefore to use sufficient horsepower and not to overload your boat beyond its ability to plane. The following table is based on experience obtained with sled type boats using the Outboard Jet. The gross weights shown include the motor, hull, fuel, people and all gear carried. For a given horsepower loading beyond these weights will give less than good performance.

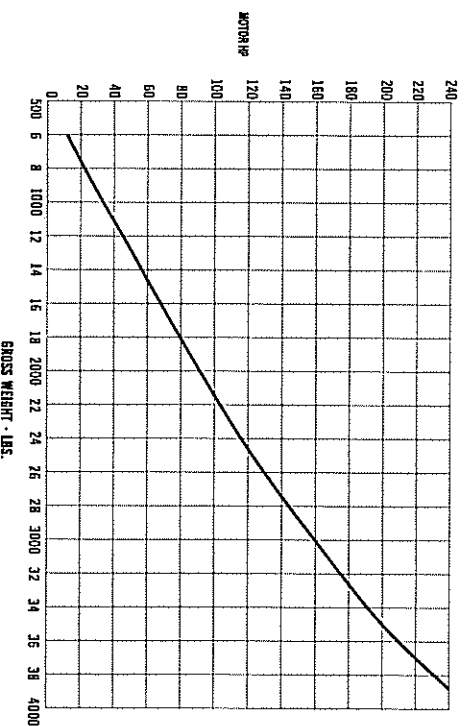

3. ASSEMBLY

Follow the assembly instructions carefully.

If your dealer has installed your jet drive for you, be sure to ask him for:

1. Assembly instructions, which include your warranty.
2. Grease gun and tube of grease.
3. Spare cotter pin, shear pins or drive keys and allen wrench, where used.
4. Be sure to check cooling water system after assembly.

4. REVERSE GATE ADJUSTMENT AND HOLDING LATCHES

If improperly adjusted, the reverse gate can be tripped into reverse by wave action, when not expected, and will cause the engine to kick up out of the water, just like hitting a log with a propeller drive.

The reverse gate linkage must be adjusted to hold the gate firmly in forward position. On units so equipped, the roller should be at the end of the slot in the cam such that the gate cannot be forcibly rotated toward reverse. Pull on the gate by hand to verify this. Do not be concerned if the gate does not fully close in the reverse position, since water pressure will close it.

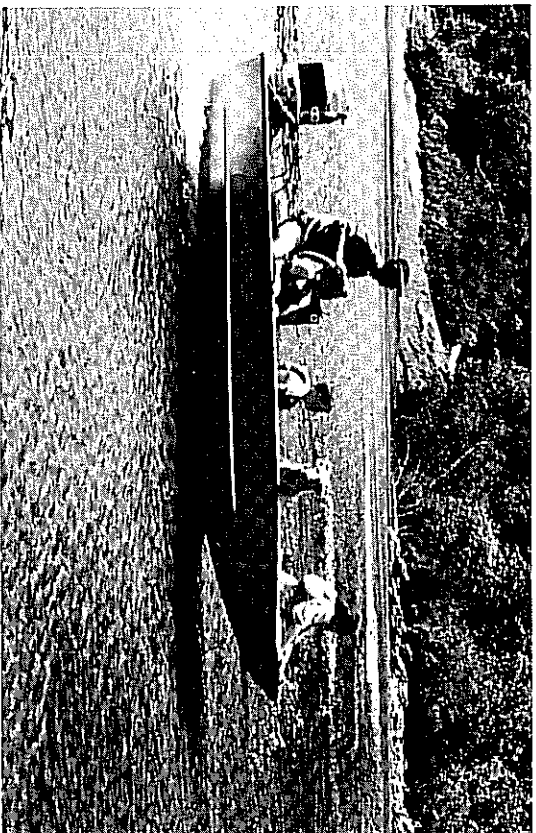

The jet drive you have just purchased will enable you to operate your boat with both a new degree of safety and in shallow areas that are inaccessible to conventional propeller drives.

Read the following carefully. The charts, instructions, and suggestions are based on years of experience and will enable you to obtain the maximum performance, service and satisfaction from your jet drive.

5. BOAT TRANSOM BRACKETS

When converting to jet drive, your motor will have to be raised to the height shown in 6 below.

A bracket with splash plate is in the works, or you can make one as shown. The height of a non-adjustable bolted bracket should allow the motor to be set $\frac{1}{2}$ inch below the height shown in 6. Then by addition of $\frac{1}{4}$ inch shims, the motor can be raised to the proper setting.

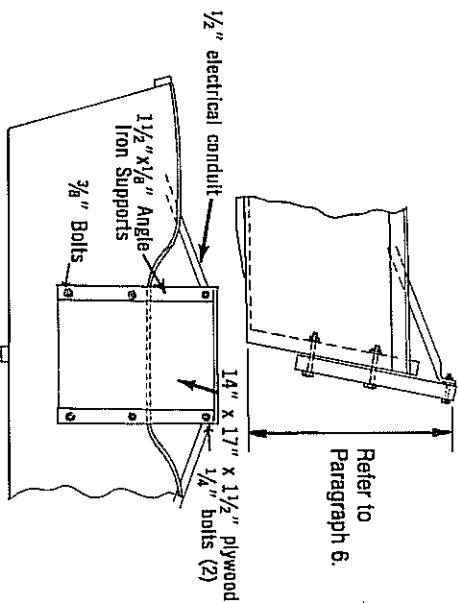
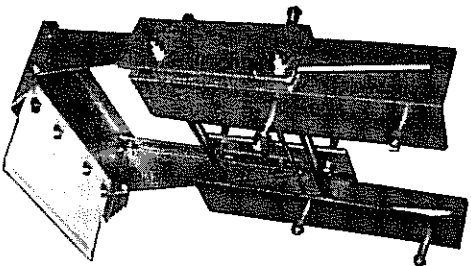

1. Glue 2 pieces $\frac{3}{4}$ inch exterior plywood together using waterproof glue. Clamp or nail.

2. Bolt to boat transom at height shown. Use zinc plated hardware with flat washers both sides.

3. Make 2 diagonal braces from $\frac{1}{2}$ inch electrical conduit. Flatten ends in vise and drill $\frac{1}{4}$ inch hole through. Attach motor mount end first. Then determine position and angle of forward bend. Attach to boat in solid location such as seats or gunwales. Avoid flexible aluminum panel locations.

6. SETTING MOTOR HEIGHT ON YOUR BOAT

The motor height is important and must be set carefully. $\frac{1}{4}$ inch above optimum setting will allow air to enter the pump resulting in cavitation and power loss. Setting too low will result in unnecessary drag, water spray and speed loss.

The initial height setting is obtained by placing a yardstick or other straight edge against the boat bottom (not the keel). The top of the leading edge of the water intake is set to line up with the top edge of the straight edge.

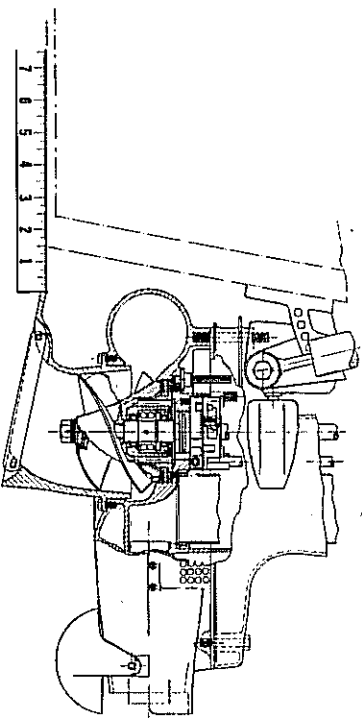

Now test run the boat. If cavitation occurs (air enters the pump causing loss of thrust, motor overspeeds erratically) then lower the engine $\frac{1}{4}$ inch at a time until smooth operation is obtained. Slight cavitation on sharp turns or in rough water is acceptable but excessive cavitation is harmful to both motor and pump and should be avoided.

If smooth operation is obtained with the initial setting you should raise the motor in $\frac{1}{4}$ inch steps until cavitation does occur. Then lower $\frac{1}{4}$ inch and lock permanently. This height setting then never needs to be changed regardless of boat load being carried.

The motor tilt pin should be set to a vertical engine position when the boat is planing. If the boat rides bow high, or tends to be stern heavy, tilt the motor down one notch which will point the jet stream down, giving added lift to the stern. If the tilt angle is changed, then the height should be rechecked.

7. FURTHER REDUCTION IN SPRAY AND CAVITATION

To reduce spray, or to further reduce cavitation in rough water, a $\frac{1}{2}$ inch splash plate can be used. This will allow mounting the motor higher to reduce drag. A set of intake fins is available to reduce cavitation when running with the wind in a chop.

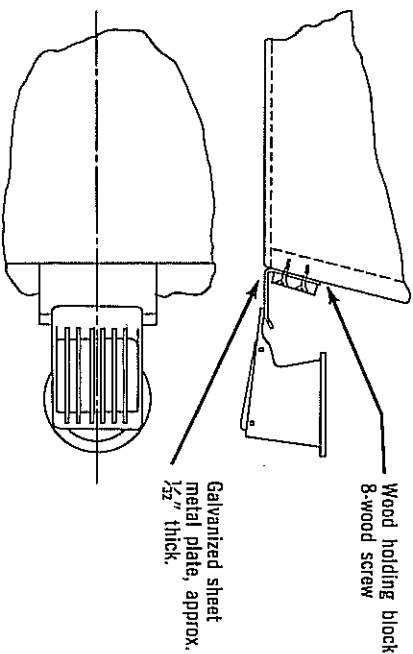
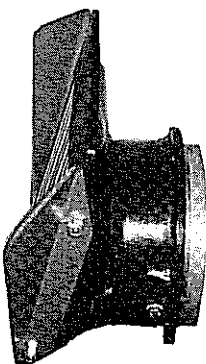
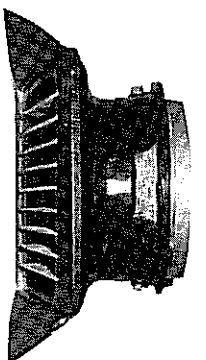

8. TIPS ON JET BOAT OPERATION

A. Experiment with steering your boat in an open area before attempting downstream river running. You will find quick response to the helm, but due to the relatively flat bottom hulls and lack of propeller skeg, your boat will tend to skid on the turns. You must start your turns early and use sufficient power to maintain steerage. If you attempt too tight a turn at too high a speed, your boat will likely spin out. This is a great way to stop in a hurry but can also cause an unstable boat to roll over.

Run at a slow idle for trolling and moving cautiously in uncharted areas. Running at $\frac{1}{2}$ speed and a steep angle is the most vulnerable position for hull damage with submerged obstructions.

For cruising, run at the least throttle that will maintain an easy plane — not a sluggish one. Go to full throttle only when necessary for minimum draft, climbing steep drop offs, starting a heavy load, etc.

When planing easily, you will slide over most any obstruction that is just below the surface, out of sight and not leaving a telltale disturbance on the surface of the water.

9. MAINTENANCE

A. Your jet drive is equipped with a shear pin or key to protect the unit in the event of a rock jam. This can be reached by removing the water intake, and then the driveshaft cotter pin and nut, similar to a propeller drive. After replacing the pin or key, pull the shaft nut up tight to remove any play between the impeller and shaft. Note the position of the impeller shim washers, and replace them in the same order.

B. A grease gun and tube of grease is supplied with your jet drive. We recommend greasing the bearing every 10 hours. Make greasing a part of your cleanup after the days use. Pump in just enough grease to fill the lube hose. Then reconnect the lube hose coupling to the zerk grease fitting.

Every 30-40 hours, pump in extra grease so as to purge any moisture. The texture of the grease coming out gives an indication of conditions inside the bearing housing. A gradual increase in moisture content indicates seal wear. If the grease begins to turn a dark, dirty grey, the bearing and seals should be inspected and replaced if necessary. Some discoloration of the grease is normal during the break-in period on a new set of seals.

We have selected a water resistant grease of the proper consistency for this application. If you use a substitute grease, be sure it is water resistant and of the same consistency.

C. Check all mounting bolts, intake screws, linkage connections, etc., occasionally to be sure they are tight.

10. SERVICE

As time goes by, more and more Outboard Motor dealers will be equipped to service your Outboard Jet.

If your dealer is not so equipped, we maintain a good supply of parts at the factory and will give your needs our prompt attention. We are now stamping both model and serial numbers on top of the cast projections that support the reverse gate pivot pins. Specify your motor make, model and horsepower in addition to jet model and serial number when requesting service.

Running upstream is the easiest. Remember that when running downstream, your speed relative to the shore is boat speed added to the speed of the river. Running upstream the river speed subtracts from the boat speed and the shore doesn't go by as fast. You can throttle back and pick your way up through tight areas with good control. At that time, you should stop and study the layout looking downstream, so that you will recognize it on the return, downstream run. Once through you may wish to run down and back up the same stretch to memorize the course you take.

If you are not sure of a tight area on a downstream run, it is better to drift through on the oars with the motor tipped up, or else line the boat through on a rope.

B. The life of the impeller and water intake can be greatly increased by avoiding the intake of sand and gravel. The intake suction, acting on the river bottom, will act like a dredge when the intake comes within 2 or 3 inches of the bottom. It is best to shut off the motor and drift up to the beach when landing, and to shove off with an oar when leaving. You can idle through areas less than one foot deep, but there should be more than one foot of water under the boat when opening the throttle to reach a plane.

Once planing, however, the boat speed will prevent sucking in gravel. The suction is still acting, but the water intake passes over the river bottom so quickly that before the rocks have time to lift, the boat is gone.

To run a shallow area, therefore, decide your course and then run through on a full plane. The faster you go, the higher the boat will ride. No problem here if the river bed is sand and gravel. If you run high and dry, shut off the motor immediately and drag the boat off to deeper water. If, however, the river bed is sharp, larger rocks, you may end up walking home.

Occasionally, on running aground, a small rock will jam between the impeller and intake wall, as the shut down motor comes to a stop. Neither the starter motor nor starter rope will be able to turn over the motor. You can either remove the 6 screws holding the water intake to free the rock or easier, remove the motor cover and rock the flywheel backwards with a screwdriver in the ring gear. Be sure to remove the sparking wires before rocking the flywheel.

Gravel passing through the pump will round over the leading edge of the impeller blades. For maximum performance file these edges occasionally to keep them as sharp as when new.

C. Occasionally, when either holding or proceeding slowly upstream in a fast moving shallow area, you will lose power. This is usually caused by suction holding larger flat rocks against the intake grill and restricting the water intake. If you will quickly stop the motor and restart it, the rocks will fall away and full power will be restored. Lily pads and paper bags can have the same effect. If, however, rocks have been jammed between the grill bars, they must be removed by wedging them out with a screwdriver.

D. If you tie your boat up by the seashore where the action of the surf causes the boat to rise and fall on the sandy beach, be sure to tip the motor up, out of the water. We neglected to do this once, and after 2-3 hours the wave action had deposited so much sand up inside and around the impeller that we could not crank the motor. No harm was done but we had to wash out the sand before we could start the motor.

E. As with any outboard, you will get maximum mileage by not running at full throttle. Neither should you run at $\frac{1}{4}$ to $\frac{1}{2}$ throttle with the boat at a steep angle leaving a large wake and wasting fuel.

Outboard Jets

DIVISION OF
SPECIALTY MFG. CO.

2035 EDISON AVE., SAN LEANDRO, CA 94577
(510) 582-6049