

# SD203 OWNER MANUAL

*SUPER DUTY JET*  
*203mm Axial Flow*

***THE POWER IS IN THE PUMP***

# OWNERS MANUAL

## AMERICAN TURBINE SD-203

### Before Operating your jet boat

Read this manual carefully. Learn how to operate your boat properly. If you have any questions, contact your dealer. Safety and operating information that is practiced along with using good common sense can help prevent personal injury and product damage.

### Boat Horsepower Capacity

Do not overpower or overload your boat. Using an engine that produces such power so that you have less than 8 pounds per horsepower can 1. Cause loss of boat control 2. Cause boat to break up from excessive power. **Overpowering a boat can result in serious injury, death or boat damage.**

### Boater's Responsibilities

The operator (driver) is responsible for the correct and safe operation of the boat and safety of its occupants and general public. It is strongly recommend that each operator (driver) read and understand this entire manual before operating the boat. Be sure at least one additional person on board is instructed in the basics of starting and operating the boat in the case the driver is unable to operate the boat. Check with you dealer before installation of accessories. The misuse of acceptable accessories or the use of unacceptable accessories can result in serious injury, death, or product failure.

### PRE OPERATION INSPECTION

The following inspection should be performed with the help from the **SELLING DEALER** prior to jet drive operation. The same inspection should be performed by the user or selling dealer after the first 10- 20 hours of use and regularly thereafter every three months. If any items of the inspection list do not meet inspection guidelines, they should be corrected before using the jet drive. PLEASE NOTE, this jet is equipped reverse sense steering, which means that your boat will operate different than an automobile when in reverse. This is easily overcome by steering in the direction you want the bow to go when in reverse.

1. **Thrust Bearing Lubrication.** The bearing is lubricated at the factory before shipment. Lubricate every thirty hours or if the boat sits for more than 2 months. Lubricate before you take it out, about 4-5 pumps in the thrust bearing. Do not force grease in the bowl bearing.
2. **Hand Hole Cover.** Check to make sure that the hand hole cover is tightly fastened.
3. **Steering.** Check the steering by rotating the wheel right and left with the engine off and verify that the nozzle turns completely against the housing to which it is attached.
4. **Reverse Shift Control.** With the control in full reverse, the reverse bucket should completely cover the nozzle's discharge opening. In full forward, the reverse bucket should clear the entire nozzle discharge opening. In neutral, the reverse bucket should cover about 3/4 of the discharge opening. The reverse bucket should have a provision to lock it in the forward position so that the bucket cannot fall into the water stream.
5. **Throttle.** Check to see that the throttle is operating smoothly.
6. **Transom Seals.** There should be no leaks at the housing seal to the boat or the housing seal to the bowl.
7. **SD-203 Weep Hole Inspection.** A weep hole is provided to indicate the condition of the mechanical seal. Water running out the hole is an indication of a failed seal or that there is foreign debris between the seal faces i.e. fishing line etc. A blast of compressed air in the weep hole will sometimes clear the obstruction. If it continues to leak, consult your dealer.
8. **Engine Cooling Connections.** Check to make sure all hose connections are tight.

### OWNERS MANUAL

1. **Trailer Launching.** Before launching make sure that all drain plugs are in place securely. To drive off of the trailer, the intake part of the jet drive should be immersed in the water. Use low speed and gentle handling when driving on or off the trailer.
2. **Starting.** Always start your boat in neutral. Warm up engine properly.
3. **Break-In Time.** The thrust bearing and the mechanical seal need break-in time to insure long life.
4. **SD-203 Weep Hole Inspection.** A weep hole is provided to indicate the condition of the mechanical seal. Water running out the hole is an indication of a failed seal or that there is foreign debris between the seal faces i.e. fishing line etc. A blast of compressed air in the weep hole will sometimes clear the obstruction. If it continues to leak, consult your dealer.

**Practice.** It is a good idea to use the recommended break-in period of the engine and jet drive to get the "feel" of your new jet drive powered boat. It should be handled in the beginning at low speeds and with gentle turns. Because of the jet drive's natural absence of torque, steering is much more responsive than propeller driven boats. Since tighter turns can be made in a jet drive boat, be sure to practice these carefully at lower speeds until you are completely familiar with the handling characteristics of your boat. PLEASE NOTE, this jet is equipped reverse sense steering, which means that your boat will operate different than an automobile when in reverse. This difference easily overcome by steering in the direction you want the bow to go when in reverse, a little practice in a safe area is recommended.

**IMPORTANT, jet boats will not steer without power to the jet.** A jet drive propelled boat has the ability to brake quickly unlike boats using a propeller that must contend with gears. At no-wake and low speeds the jet driven boat maybe halted by pulling the control into reverse. **Shifting into reverse at planing or high speed, can result in serious injury, death or boat damage.** PLEASE NOTE, this jet is equipped reverse sense steering, which means that your boat will operate different than an automobile when in reverse. This is easily overcome by steering in the direction you want the bow to go when in reverse, a little practice in a safe area is recommended.

## GENERAL MAINTENANCE

- 1. Lubrication.** Thrust bearing; inspect regularly, at least every thirty hours of operation or if the boat sits for more than 2 months. Grease the thrust bearing before you take it out. Lubricate the thrust bearing using VALVOLINE SYNTHETIC # 985, or the equivalent. Grease must be EXTREME PRESSURE, HIGH TEMPERATURE, and must contain MOLY. NOTE: DO NOT USE WHEEL BEARING GREASE. Bowl bearings, lubricate at the time of winterization, summerization, and once midway through the boating season. Use the same grease as the thrust bearing. The grease zerk is located at the discharge end of the jet drive. Access to the grease zerk is through the nozzle, a long extension on your grease gun will be required. NOTE: Be sure to grease the bearing before your first outing in the spring. Most thrust bearing failures occur then.
- 2. Reverse Components.** The reverse bucket should be inspected every thirty hours for proper function. The reverse bucket should not have any play when the cable is under tension. The cable attaches to the reverse bucket with a pivot pin. Make sure this attachment is secure. Also make sure that the reverse cable is secure where it passes through the bracket. Adjustments to the reverse bucket position can be made by tightening the bulkhead fasteners at the bracket
- 3. Steering.** You should check all steering cable connections, each trip for safety. These include the transom housing steering nut, the tiller arm-to steering tube connection, the tiller shaft set screw and the lower nozzle pin cap screw
- 4. Hand Hole Cover.** Check the hand hole cover for tightness periodically.
- 5. Lack of Performance.** If the pump over revs when trying to get on plane, it is probably due to a stick, leaf or something else in the impeller eye. Remove any foreign material from the impeller. **REMOVE THE IGNITION KEY BEFORE PLACING YOUR HAND INSIDE THE JET DRIVE.**

## PRECAUTIONS AGAINST CORROSION

- 1. Salt water operation.** The SD203 is designed for a trailer boats and is not intended for boats that are moored in salt or brackish water. It can be used in salt water but must be flushed with fresh water after daily use. It is recommended that your SD203 be disassembled down to the impeller and remove all signs of corrosion and coat all mating parts with an anti-corrosion compound such as LANOCOTE. Also steering parts need to be cleaned and coated.

## SAFETY

- 1. Retrieving Skiers.** We recommend shutting off the engine when retrieving downed skiers.
- 2. Ski Ropes.** Ski ropes should be avoided if possible to insure that they are not sucked into the pump. Should you run over the rope turn the engine off immediately. Shut off the engine while retrieving the rope. There is a certain amount of danger in retrieving the rope with the engine running, i.e. should the line be sucked up and a person become entangled it could be possible for them to be drawn under water and drowned. **REMOVE THE IGNITION KEY BEFORE PLACING YOUR HAND INSIDE THE JET DRIVE.**
- 3. Shallow Water Operation.** When the boat is operated in shallow, rocky water, ingestion of small rocks can cause damage to internal parts. No system can keep all the debris and rocks and allow enough water through to operate properly. So, remember to be careful in rocky water.
- 4. Braking At Speed.** Be sure to use the braking action conservatively because the effect is much the same as an emergency stop in an automobile.
- 5. Engine Cooling.** Do not operate the engine out of the water as severe damage to the engine and jet drive could result.

## LIMITED WARRANTY

- American Turbine, Inc. warrants, to the first original retail purchaser, each new jet drive unit manufactured by American Turbine, Inc. to be free from defects in material and workmanship.
- The warranty extends for 12 months from the date of purchase.
- Claims under this warranty shall be made by returning the defective part freight prepaid to American Turbine, Inc.
- Any jet drive or part determined to be defective in either workmanship or material during the warranty period will be repaired or replaced at American Turbine, Inc.'s option, without charge for parts or labor. American Turbine, Inc.'s liability shall be limited to repairing or replacing part found to be defective during the warranty period.
- American Turbine, Inc. reserves the right to change or to improve the design of any product without assuming any obligations to modify such units previously manufactured.

## EXCLUSIONS AND LIMITATIONS

This warranty does not apply to:

- Any part, accessory or product not manufactured by American Turbine, Inc., And for which Manufacturer warranty has been supplied to the consumer by the respective manufacturer.
- Normal Maintenance items such as lubrication and adjustments necessary as a result of normal wear and tear.
- Any jet drive or part that has been modified, altered, or repaired by other than American Turbine, Inc.
- Products damaged as a result of misuse, neglect, negligence, accident, freezing, normal wear and tear, corrosion, **salt water corrosion**, improper installation, operation with lubricants which are not suitable for use with the jetdrive, failure to operate and maintain the product in accordance with the owner's manual supplied with each new American Turbine product, products used for racing, damage resulting from debris, or other substances entering through the jetdrive, operating the jetdrive at RPM in excess of the maximum rated RPM as stated in the owner's manual, or any case other than a defect in the manufacture,

material, or assembly of an American Turbine, Inc.

5. American Turbine, Inc. shall not be liable for any incidental, consequential or other damages whatsoever, including but not limited to: loss of use, loss of time, inconvenience, cost of returning the defective product to American Turbine, Inc., travel, lodging, or damage to personal property.

6. Some states do not allow the exclusion or limitation of incidental or consequential damages, so the above limitations may not apply to you.

7. This warranty is the only express warranty applicable to American Turbine, Inc. products, and is in lieu of any other express or implied warranties, including warranties of merchantability and fitness for a particular purpose. All implied warranties are limited in duration to minimum period required by State law. American Turbine, Inc. neither assumes or authorizes any other person to assume for it any other liability or warranty in connection with its products,

8. Some states do not allow limitations on the duration of implied warranties, so the above limitations may not apply to you.

9. This warranty gives you specific legal rights, and you may also have other rights which may vary state to state.

## UNDERSTANDING YOUR BOAT

Most boat owners like to perform at least a certain amount of their boat maintenance themselves to ensure continuing good performance and reliability.

To avoid unnecessary trips to the service center, it might be useful to have a checklist, which can be run through systematically, in the hope of pinpointing the problem quickly. The boat can be divided into three categories - jet unit, engine, and hull.

If something is "wrong" with the boat it is usually poor acceleration and load carrying, coupled with excessive fuel consumption or engine RPM's. It could be unusual noise coming from the mechanicals, or possibly just poor top speed. All of these things may be present to some degree, but the usual complaint is that the boat is just plain "gutless".

### **TACHOMETER**

The most important single instrument on the boat when considering performance drop-off is the engine tachometer.

The great thing about jet boats is that the engine RPM's should remain the same throughout the life of the boat, regardless of age, loading, water conditions, towing, whatever.

There is no situation where the RPM's should be different from when the boat was new, and as an owner, you will know what these are. At any time, you should be able to open the throttle fully and get exactly the same maximum reading you have been used to. Or perhaps you are finding it needs more RPM's to cruise your normal load? RPM's are a most important indicator of proper operation of the boat.

It is important at this stage to feel confident that your tachometer is reading accurately.

Now we come to our check list, and determination of which major area is the problem. The simplest way is a check on the RPM's first. They could be normal, high, or low, and this will pin point the place to look:

### **A. Normal maximum RPM = hull problem.**

If the boat is performing poorly and the maximum RPM's are normal and what you are used to, you can look to the hull and some of the external parts. These include:

1. *Overload*: Too much weight aboard.

2. *Balance*: Either too much weight aft, which will cause the nose to be too high and make planing difficult, or if the weight is too far forward, it will cause the nose to plow, difficult steering, wetness, and poor top speed.

3. *Reverse bucket*: Is the bucket dragging in the reverse stream? Make sure the control is fully up.

4. *Excessive hull drag*: Is there some external hull obstruction such as rough surface, broken keel strips, or other reason impeding the smooth flow of water over the hull bottom? A visual check on the trailer should reveal if there is. Metal hulls can have a "hook" bashed into them forward of the transom which can cause the bow to plow. The planing surface forward of the transom six to nine feet should be true and flat.

### **B. High rpm = jet unit problem.**

Higher than normal RPM's, lack of thrust, slipping clutch feel, engine racing and no go?

1. *Blockage*: The most common problem is weeds and stones blocking the intake grate. Also be aware of ski rope, fishing line and plastic bags winding around the pump shaft. Small sticks and stones can become lodged in the impeller affecting the performance

dramatically, objects trapped in the impeller can cause the rotating assembly to be out of balance, causing severe vibration. Make sure the water passage through the jet is clear.

2. *Impeller wear*: The heart of the jet is the impeller, and its condition. If you run in shallow gravel beds or across sandbars the leading edges will become dull and inefficient. Pumping sand will increase the wear-ring to impeller clearance. Causing cavitations and loss of performance.

3. *Bowl / stator vanes*: It's not too much of a problem, but the leading edge of the fixed stator vanes can become blunt and damaged.

4. *Air leaks*: If excessive air leaks into the intake ahead of the impeller, the jet unit will "slip". Possible sources of air leaks are through a faulty gland seal, which is usually accompanied by a static water leak into the boat when standing idle.

So if the gland is worn out and leaking into the boat with the engine off, it can also suck air when accelerating on to plane, and if this happens, then the thrust is reduced dramatically. Air can also be introduced into the system via the inspection cover, so you will want to make sure the cover is tight.

### **C. Low RPM = engine problem**

There is generally no way the jet unit can overload the engine and bring the RPM's down. If the RPM's are down from usual, it is almost certain to be an engine problem. A compression check will usually reveal leaking piston rings or valves,

but the most common reasons for reduced engine power are:

1. *Throttle*: Check that the throttle is opening fully.
  2. *Fuel*: The fuel supply must be adequate for the engine size. Racing boats frequently have a fuel pressure gauge which is, with the tachometer, probably the most important engine instrument. Sufficient fuel must be reaching the engine.
  3. *Air to the engine*: The carburetor must be getting its full quota of cool air. If the engine has to work to get adequate air, and if it is hot air, this will reduce power.
  4. *Ignition spark*: Be satisfied the ignition system is operating properly. A problem here is usually indicated by a rough running or missing engine.
  5. *Exhaust*: Check for a free flowing exhaust system. Some silencers can become blocked, rubber hoses disintegrate internally, or there is excessive water injection. Such things can cause excessive back pressure and reduce power.
- Provided your engine is getting its full quota of air and fuel, and is getting enough spark and at the right time, the engine will usually be OK, and maximum RPM's will result. However if the RPM's are down and you believe the tachometer, look for an engine problem. The hull, engine, and jet unit are the three main areas to look at when your performance is down.

**D. Excessive noise.**

This can often be a concern even if there is not a reduction in performance. The most common causes of noise are:

1. *Cavitation*: The jet unit is starved for water, and usually sounds like a rattle or a can of loose bolts in the back of the boat. Most likely a blocked intake grate.
2. *Moan or whine*: The jet unit can exhibit some "turbine whine" not unlike a turbocharger noise but you will know what is usual with your boat. However, if you have a new more obvious moan/whine, especially if it is a very low frequency grumble at idle, that increases with engine RPM's then it is likely to be a rough/worn/water damaged thrust bearing. If water has gotten into the bearing, it is usually as a result of a flooded bilge at some time on a warm bearing, then water can be sucked in as it cools.
3. *Periodic vibration*: Often at specific RPM's and disappearing at other throttle openings is probably a torsional vibration emanating most likely from the universal joints on the drive shaft.

**AMERICAN TURBINE**

3692 RIVERSIDE DR.  
CLARKSTON, WA 99403  
PHONE: (509) 243-5387  
FAX: (509) 243-5391

INTERNET: WWW.AMERICANTURBINE.COM

**WARRANTY REGISTRATION**

1. Owners Name \_\_\_\_\_ Phone Number \_\_\_\_\_
2. Address \_\_\_\_\_ City \_\_\_\_\_
3. State \_\_\_\_\_ ZIP \_\_\_\_\_ E-mail \_\_\_\_\_
4. Dealer Name \_\_\_\_\_ Dealer Phone Number \_\_\_\_\_
5. Jet Drive Model \_\_\_\_\_ Serial Number \_\_\_\_\_
6. Engine Make \_\_\_\_\_ Size \_\_\_\_\_
7. Boat Make \_\_\_\_\_ Model \_\_\_\_\_ Length \_\_\_\_\_
8. Primary Use - Pleasure-----Commercial-----Freshwater-----Saltwater
9. Pre-Delivery Inspection Completed \_\_\_\_\_ Yes \_\_\_\_\_ No Date \_\_\_\_\_ Inspection must be completed by Dealer
10. Date of Sale \_\_\_\_\_ Date Put in Service \_\_\_\_\_
11. Owner Signature \_\_\_\_\_ Date \_\_\_\_\_
12. Dealer Signature \_\_\_\_\_ Date \_\_\_\_\_

This Warranty Card must be completed and mailed to American Turbine. The jet drive warranty is void if registration is not mailed within 15 days of date of sale.

**AMERICAN TURBINE**

3692 RIVERSIDE DR.  
CLARKSTON, WA 99403

# American Turbine SD203

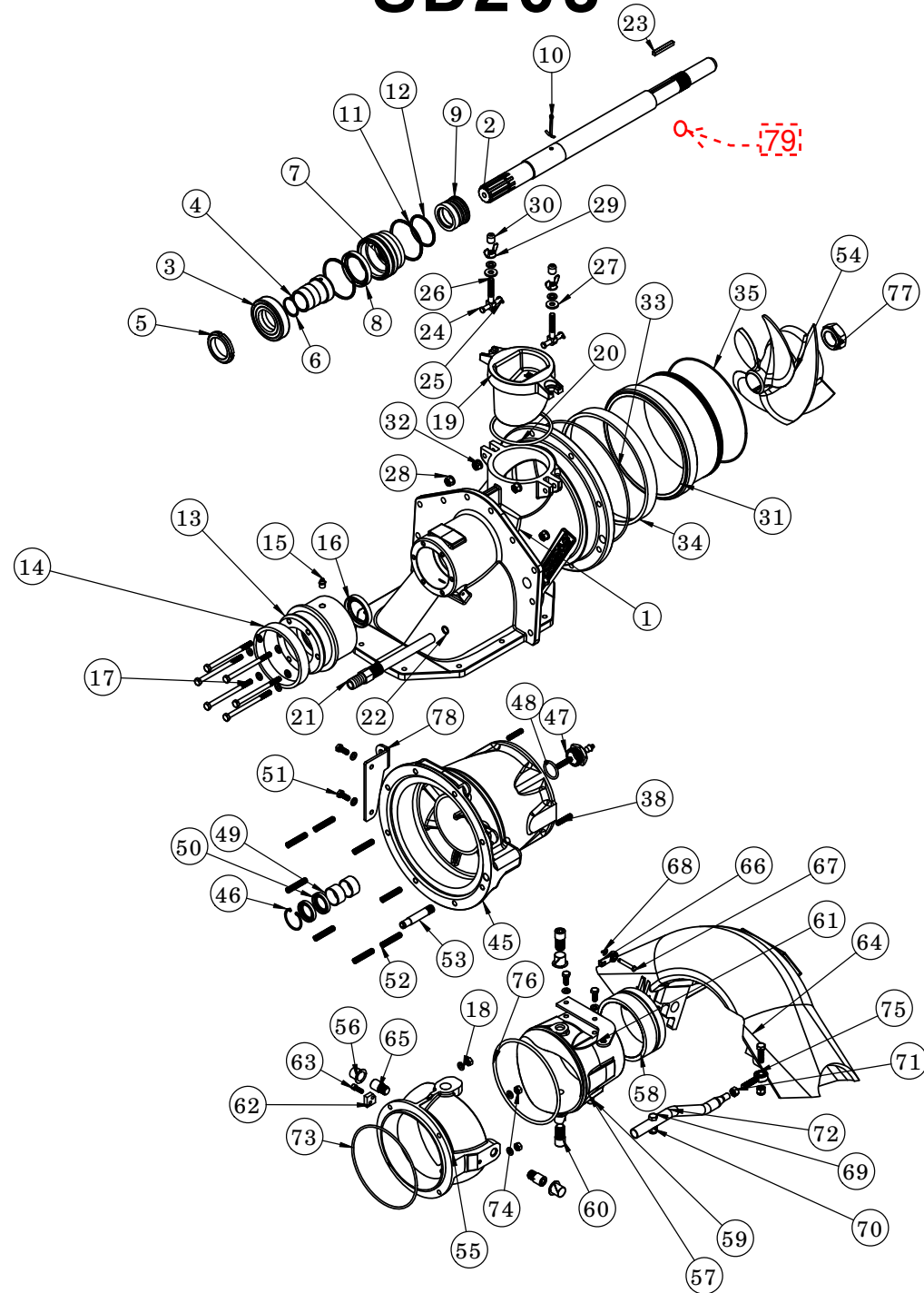

# American Turbine SD203

ITEM #	DESCRIPTION	PART #	QTY.	ITEM #	DESCRIPTION	PART #	QTY.
1	SUC TION PIECE, SD203-312	SC 1401	1	40	5/16 -18 LOCK NUT	F05 18 LN	4
2	PUMP SHAFT, SD203, 309, 312	SH1207	1	41	O-RING, INTAKE, SD-312	O 3901	1
3	THRUST BEARING (SD & FW)	B1101	1	42	5/16-18 X 1 HEX HEAD CAP SCREW	F05 18 08 HH	2
4	BEARING SLEEVE, SD203, 309, 312	SH5001	1	43	5/16 FLAT WASHER	F05 FW	10
5	NUT, BEARING SLEEVE, SD203, 309, 312	SH5101	1	44	5/16-18 X 1-1/4 HEX HEAD CAP SCREW	F05 18 10 HH	8
6	SNAP RING, SHAFT	SH1507	1	45	STATOR, SD203	SC 9312	1
7	SEAL FACE HOUSING, SD203, 309, 312	SH5201 ALUM	1	46	BO WL SNAP RING	SC 9201	1
8	SEAL, SEAL FACE HOUSING	SL1201	1	47	BO WL PLUG	SC 9001	1
9	SEAL, MECHANICAL (SD & YJ)	SL4008	1	48	O-RING, BO WL PLUG	O 2203	1
10	5/32 X 2 CO TTER PIN	F03 16 C P	1	49	BO WL BEARING, GREASE LUBE 3/4	B1502	2
11	O-RING, BEARING HOUSING, SD203, 309, 312	O 3301	2	50	SEAL, BO WL (AT, BERK, LA TE DO M)	SL2003	2
12	O-RING, SEAL FACE HOUSING, SD203, 309, 312	O 3401	1	51	5/16-18 X 3/4 HEX HEAD CAP SCREW	F05 18 06 HH	4
13	BEARING HOUSING, SD203, 309, 312	SC 2101	1	52	3/8-16 X 2 SET SCREW	F06 16 16 SS	8
14	ENGINE MOUNT RING (BEARING CAP)	SC 4007	1	53	NIPPLE, WATER CO O LING TUBE (SD203, 312)	SC 4101	1
15	GREASE ZERT	SC 8901	2	54	IMPELLER, STAINLESS, AXIAL, SD203AF, 2.8KW	IMX203-280	1
16	SEAL, BEARING HOUSING SD203, 309, 312	SL1101	1	55	NOZZLE HOUSING, SDR (SD203)	SR1007	1
17	5/16-18 X 4-1/2 HEX HEAD CAP SCREW	F05 18 36 HH	6	56	NYLINER BUSHING, SPLIT (3/4) (WJ STR, HVR)	B2007	4
18	5/16 LOCK WASHER	F05 LW	24	57	SDR, NOZZLE, (AXIAL FLOW)	SR1009	1
19	HAND HOLE COVER, SD203, 312	SC 1801	1	58	NOZZLE INSERT, AXIAL, SIZE 4.200	SR7420	1
20	O-RING, HAND HOLE COVER, BERK, SD & FW	O 1002	1	59	5/16-18 X 1/2 SOCKET HEAD CAP SCREW	F05 18 04 SH	1
21	WATER TUBE, (SD203, 312)	SC 4201	1	60	5/8-11 X 1 SOCKET HEAD CAP SCREW W/ 5/8 PIVOT HEAD - TYP 304	R3702	2
22	O-RING, WATER TUBE, SD203, 312	O 3801	1	61	SDR, TILLER ARM, (AXIAL)	SR3009	1
23	IMPELLER KEY	SH3007	1	62	BUCKET STOP, SDR REVERSE BUCKET	SR5101	1
24	5/16 C LEVIS PIN	F05 CL	2	63	1/4-20 X 3/4 SOCKET HEAD CAP SCREW	F04 20 06 SH	1
25	7/64 X 3/4 CO TTER PIN	F02 04 C P	2	64	SDR, REVERSE BUCKET	SR2101	1
26	3/8 EYE BOLT	F06 EB	2	65	5/8-11 X 5/8 SOCKET HEAD CAP SCREW W/ 3/4 PIVOT HEAD - TYP 304	R3703	2
27	3/8 THICK WASHER (SD HAND HOLE COVER)	F06 TW	2	66	1/4-28 STAINLESS FEMALE ROD END (BEST, JET TRIM)	F04 28 FRE	1
28	3/8 LOCK WASHER	F06 LW	10	67	1/4 C LEVIS PIN	F04 CL	1
29	3/8 WING NUT	F06 WN	2	68	5/64 X 3/4 CO TTER PIN	F01 06 C P	1
30	VINYL CAP, 3/8	M5001	2	69	3/8-24 X 1-1/4 HEX HEAD CAP SCREW	F06 24 10 HH	2
31	WEAR RING, SD203AF, STAINLESS STEEL	WR203SS	1	70	3/8-24 LOCK NUT	F06 24 LN	2
32	3/8-16 HEX NUT	F06 16 HN	8	71	3/8-24 HEX NUT	F06 24 HN	1
33	O-RING, SD-312 BO WL	O 4001	1	72	SDR OFF-SET STEERING EXTENSION, SS TUBING	SR6101	1
34	WEAR RING INSULATOR (SD203, 312)	WR6005	1	73	O-RING, NOZZLE HOUSING, SD191, SD203, T1191	O 5001	1
35	O-RING, WEAR PLATE, SD203AF	O 5172	1	74	5/16-18 HEX NUT	F05 18 HN	4
36	INTAKE, WELD-IN, SD-312	I1401	1	75	3/8-24 MALE ROD END	F06 24 MRE	1
37	GRATE, INTAKE, SD203, 312	H401	1	76	O-RING, TEFLO N, NOZZLE, SD203	O 5363T	1
38	5/16-18 X 1-1/2 SET SCREW	F05 18 12 SS	8	77	IMPELLER NUT	SH3507	1
39	5/16 AN FLAT WASHER	F05 AN	4	78	SDR REVERSE CABLE BRACKET, AXIAL FLOW	SR2009 REV 3	1

**79 IMPELLER SHIMS SHK4007 1**

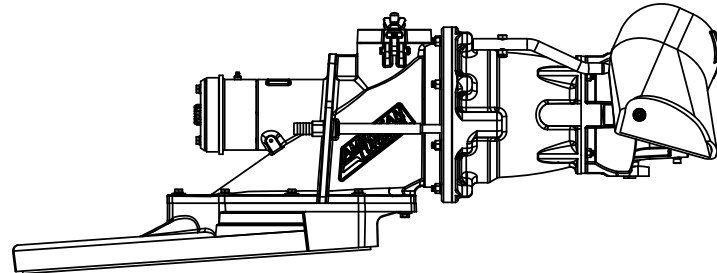

# American Turbine SD203

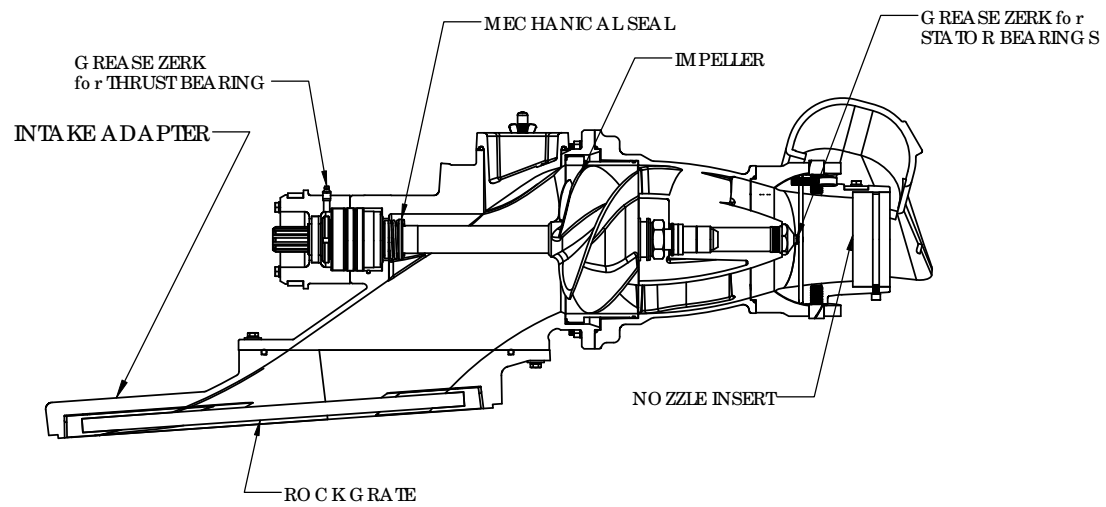

# American Turbine SD203

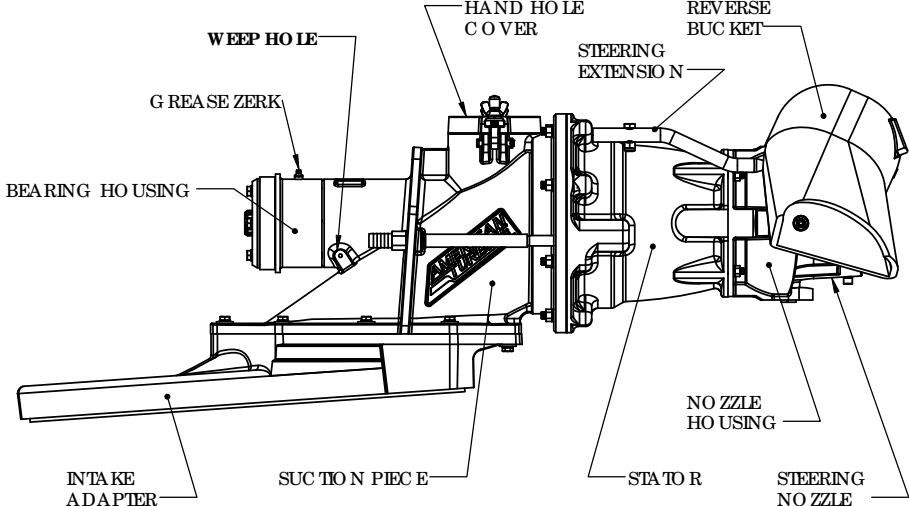

# SD203 SPECIFICATIONS

PUT STRAIGHT EDGE  
ACROSS WEAR RING. SHIM IMPELLER  
TO 0.030 FORWARD FROM THE BACK  
OF THE WEAR RING.

## FASTENER TO REQUIRE

1/4" 10 FT/LBS

5/16" 15 FT/LBS

3/8" 20 FT/LBS

1/2" 40 FT/LBS

5/8" 45 FT/LBS

USE HIGH STRENGTH

LOC-TITE ON ALL

STEERING FASTENERS

## IMPELLER / WEAR RING SPECIFICATIONS

Wear ring I.D. 8.005-8.000"

Impeller O.D. 7.955-7.950"

Clearance between impeller and  
wear ring .045-.055"

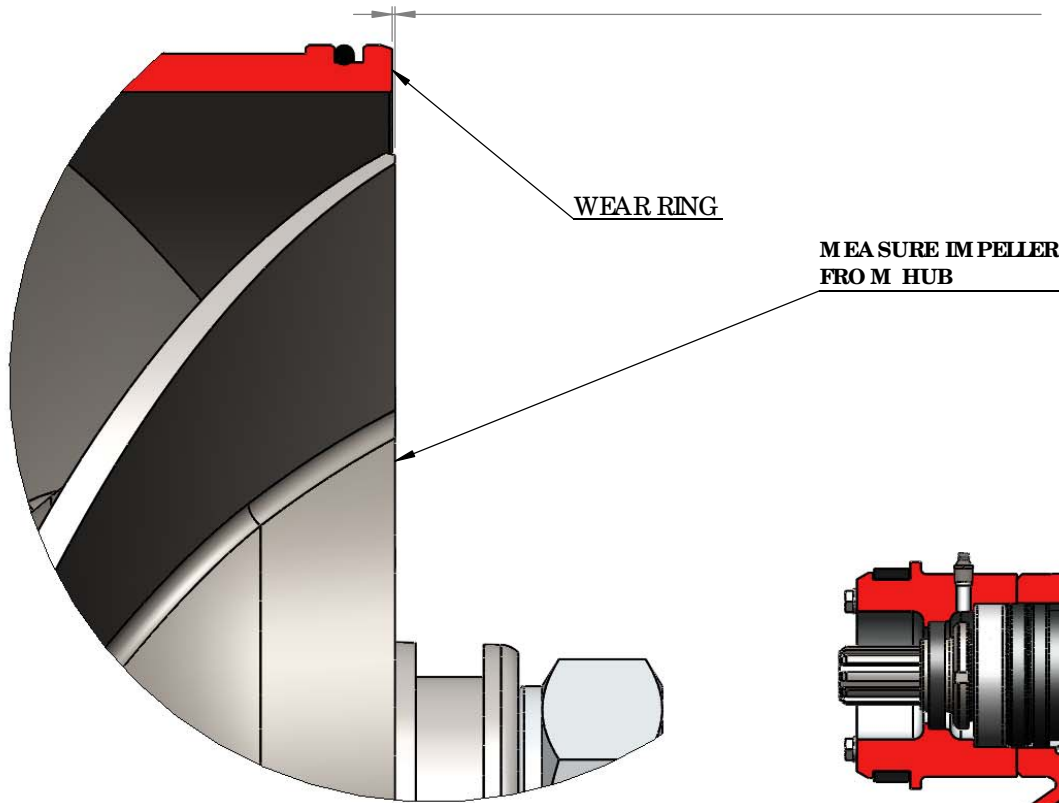

DETAIL A

